

SPARK ISSN 2277-4866

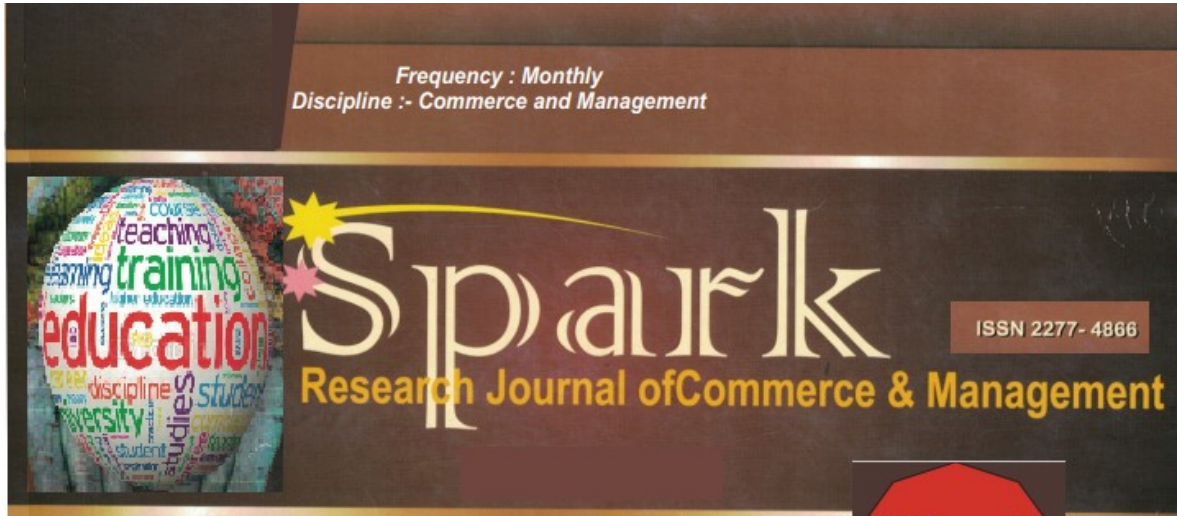

EDITOR-IN CHIEF

Dr. L.M. Dani

EDITORIAL BOARD

Dr. M. G. Shrihati

Dr. Shamasuddin Naikwad

Dr. Aman Gupta

Dr. Anil Kumar

Dr. Swati Padoshi

Dr. Rupali Taru

PEER REVIEW COMMITTEE

Dr. Surendar Kumar

Dr. B.S. Gaikwad

Dr. Jaideep Sharma

Dr. Srinivan Iyer

Dr. Hiren Daund

Dr. Neeraj Basotia

Dr. Mukesh Kumar

Dr. Harish Purohit

Dr. Swapnil Kale

Dr. Saurabh Singh

FROM THE CHIEF EDITOR'S DESK



Today corporate India is adapting a relaxed and casual work atmosphere, however This does not Mean that a friendly work environ implies lack of professional Approach Professionalism plays a Key role in your growth as a professional. It is a passive force that keeps you in the limelight. **“The only successful beings in any field, including living itself are those who have a professional Viewpoint and make themselves and ‘are’ professionals -L Ron Hubbard,** In simple words, the above quote would mean ‘to be successful, it’s important to be professional’. Being a professional means conducting yourself appropriately in a corporate set-up. It is a passive force that keeps you in the limelight.

Know your profession inside out. You must know the technical details along with the bigger picture and future directions of your field. Keeping yourself updated with the latest developments is a must in order to do well in your chosen field. There is no denying the fact that **self-learning** is of utmost importance if you want your career to head in a positive direction. Employers today want employees who can work on **multiple tasks and deliver on time**, thus stressing on the importance of multi-tasking and time management. While **setting goals for you**, be realistic and ask yourself if they are conducive and achievable. Handling distractions comes with practice. Keep identifying what hinders yours at work and experiment with ways of overcoming them. Remember, although you may seek guidance, only you can discover what you need to do. What works for one individual, may not be as effective for the other. The **courage to handle criticism** and the desire to excel should be a part of the daily work culture. Also with the nature of work activity getting increasingly integrated, employees are required to work in close synergy with teams that can be very disparate. Having a vision helps you navigate through a lot of corporate hurdles. The **vision is your yardstick for success**, a target for focus and a horizon for purpose. **Being organized** at work pays rich dividends. It saves your time and prevents stress and helps you accomplish more tasks within a less time span. Try to make your work environment clutter free and never waste time on trivialities.

Dr. L.M Dani

Editor-in Chief, (Spark)

INDEX

1	PEOPLE IN INDIA, AFRAID TO INVEST IN STOCK MARKET Shahbaz B Khan	3-11
2	THE IMPACT OF E- PHARMACEUTICAL INDUSTRY IN INDIA PROF. RAVI AHUJA	11-16
3	A STUDY OF FOREIGN DIRECT INVESTMENT IN INDIAN PHARMACEUTICAL SECTOR Atul S Pandey	16-19
4	UNDERSTANDING E-CRM AND TRENDS IN 2020 Mr. Adusupalle Muni Raju	20-25
5	COMMERCIAL CHALLENGES MANUFACTURING THROUGH LESER PROCESSING MANAGEMENT Vaishali Deshmukh	26-29
6	A Study of Patriarchy and Masculinity and its impact on the modern Indian Society Divya Alok	30-36
7	Performance appraisal process involves in retail industry Neha Upadhyay	37-40
8	REVISITING WOMEN THROUGH GOVERNMENT SUPPORTING SCHEMES Mohd. Javed	41-45
9	The impact of IFRS on financial statement disclosures by Indian Firms Ajay Lunawat	46-50
10	WEB AND TOOLS OF ONLINE DIGITAL MARKETING ABHIJEET BALASAHEB THANGE	51-53
11	A Study on the effect of Covid-19 prompting diminished active work and influencing the emotional well-being of people Ms. Aarti Amar Ahuja	54-57
12	WORK LIFE BALANCE FOR GREATER EFFICIENCY & EFFECTIVENESS ARUN K DATAR	58-59
13	A RESEARCH ON THE CHALLENGES OF WOMEN EMPOWERMENT THROUGH MICROFINANCIAL PERFORMANCE WITH RESPECT TO WOMEN SELF-HELP GROUPS IN THE NCR RAM NARAYAN SAINI	61-65
14	WORK-LIFE BALANCE OF NURSES OF SUPERSPECIALITY HOSPITALS AT HYDERABAD Shahnaaz Sultana	66-71
15	Role of Emotional intelligence in for gaining competitive advantage Tejasvita Singh	72-75
16	THE CASE FOR CATHARSIS Tanu Puri	76-81

17	THE ACCOUNTING PRACTICES IN BUSINESS OF WEST BANGAL MANOJ KUMAR ROONGTA	82-83
18	EVALUATE THE PURCHASING BEHAVIOUR IN PHARMA INDUSTRY PHATAK KETAKI MOHAN	84-86
19	PIONEERING INNOVATION Saniya Afzal	87-90

PEOPLE IN INDIA, AFRAID TO INVEST IN STOCK MARKET

Research Scholar - Shahbaz B Khan

Reg.No.- 20119037

E-Mail:-shahhan1991@gmail.com

ABSTRACT:-The Project objective is to get an insight of, why there are very less number of investors in financial market. A holistic assessment of its impact on the India's economy as well as impact on different business functions and activities. So brief objectives are:-

- To find out reason behind less number of investors.
- To analyze the impact of under developed financial market on other economic activities.

Study is designed to enable us to understand how these issues are going to impact nation's development, capital formation, capital requirement, IT technology and trading terminals and would draw the attention of management on exactly how this would impact their particular market Capitalization and market value. The survey also attempts to find out the impact of, fear in people regarding investing in equity market on economic performance, capital raising, companies market capitalization, consumer spending's. The study also analyses the less investor effect on economic performance. The parameters such as knowledge, trust, patience and skill, poor broker services are used to evaluate why people afraid of investing in stock market and subsequently how less number of investors affects other economic activities of India. Primary data are collected through email response to structure questionnaires sent to various professionals consisting traders, teaching professionals, service and job class group investors, Businessman and general public. Pointed questionnaires sent to what Sapp groups through Google form. Secondary data was collected from various internet sites, broker's database, market regulators data and various articles, Journals and newspaper. The findings suggest that post covid crisis the Economy will move towards growth, strengthening of market, investor's friendly eco system, Ease of raising capital for businesses. The other finding is that the authority should focus on further development of financial market and Data analytics for proper trend analysis.

Introduction:-Around 30 years of data available for the [Indian stock market](#) makes one point clear: Over the long haul, the stock market has been a great place to grow your wealth, with returns averaging around 18% per annum over a 30 year period.

In China, around 10% population of the common people participates in the stock market. Further, in the USA, this percentage is as high as 18%. In India Of a population of over one billion, barely 18 million invest in equity markets. According to Sebi data, 10 cities contributed over 80% of trading volume in 2010. The number of individual investors has been increasing at a 10-year CAGR of 11%. Also 17 lakh new investors in FY09 to 28 lakh new investors in FY19. Of about the 7,800 scrips listed on the Indian stock markets, less than 3,000 are actively traded. Recently, both Sensex and Nifty fell by over 15% in just 25 sessions. There are two main reasons for this irrational pattern. First, equity derivatives instruments are not linked to the underlying asset because of the very nature of cash settlement (by business today). Equities account for just 12.9% of investments in India – compared to 26.1% in the rest of the world. As per the SEBI, less than 5% of Indian households own stocks or related investments. That leaves 95% that do not. India has over 6000 companies, making the equity market the largest in the world in terms of number of

listed companies. In fact, it has a settlement cycle of T+2 with average daily traded volumes of AU\$4.5bn and a market cap larger than Australia at over AU\$2t.

Ignoring short-term price volatility, In Australian dollar terms, India has delivered returns of 12.7% p.a. compared to the S&P500's 5.3% p.a. over the last 15 years which equates to 385% difference over the period.

The World Bank in its report titled "Doing Business 2015 Going Beyond Efficiency" has ranked India 8th in respect of minority investor protection ahead of countries like the US and Australia.

Methodology

Research tool:-The tool used in the study is observation and interview schedule.

Ethical Considerations-None of the respondents was forced to give the interviewed. All of the respondents were made sure that this information will not be used against them or will not be misused anywhere. All of the respondents were made sure that none of their real name will be revealed. These respondents were familiarized with the topic. They were informed that proper Confidentiality will be maintained.

Sources of Data

The study has been carried out using both primary and secondary data. The major findings have been placed out with the help of primary data analysis.

- **Sources of Primary Data**

The primary data was collected through Questionnaires sent via email and Google Forms to people in concern and we also consulted some experts about it

- **Sources of Secondary Data**

The Secondary data includes articles, journals, newspapers, etc. The usage of existing literature is important to provide a different perspective on the topic on research. Data Available with Stock exchanges and various regulatory agencies.

Response Rate & Statistics:-The response rate is about 75%. I have approached to almost 200 respondents of various group and received a response from 150 respondents. Up to 40% of respondents are from a single state but 60% of the respondents are from more than one States. The reason of non- response from 50 are respondent's other priorities as well as paucity of times at surveyor's end for repeated follow up with the respondents.

No respondents Approached	200
Response Received	150 (75%)

DATA AND FINDINGS

Sex ratio of respondents

Sex	No. of respondents
Male	90
Female	51
Preffered not to reveal	9

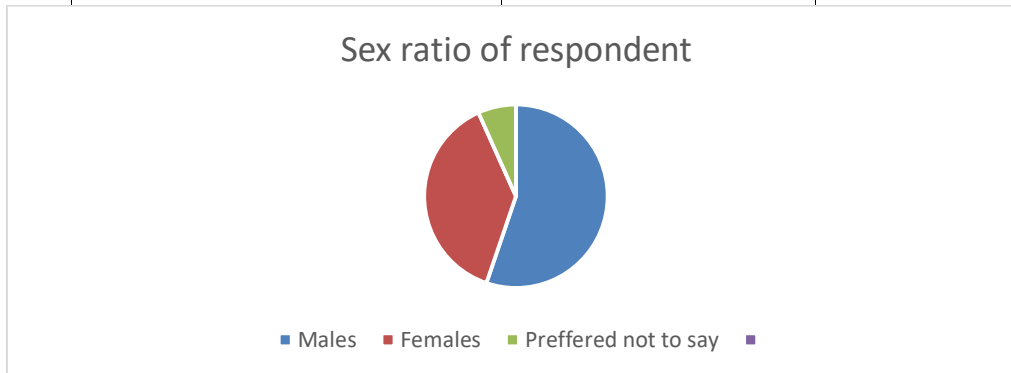

136 respondents were taken into consideration for the study

- Out of the 150 Survey Respondents, 90 are Male. (60%)
- Out of the 150 Survey Respondents, 51 are Female. (34%)
- Out of the 150 Survey Respondents, 9 preferred not to reveal their gender. (6%)

Age group of the respondents

Age Group	No. of respondents
Under 20 Years	14
20-30Years	96
30-50 Years	32
50+	8

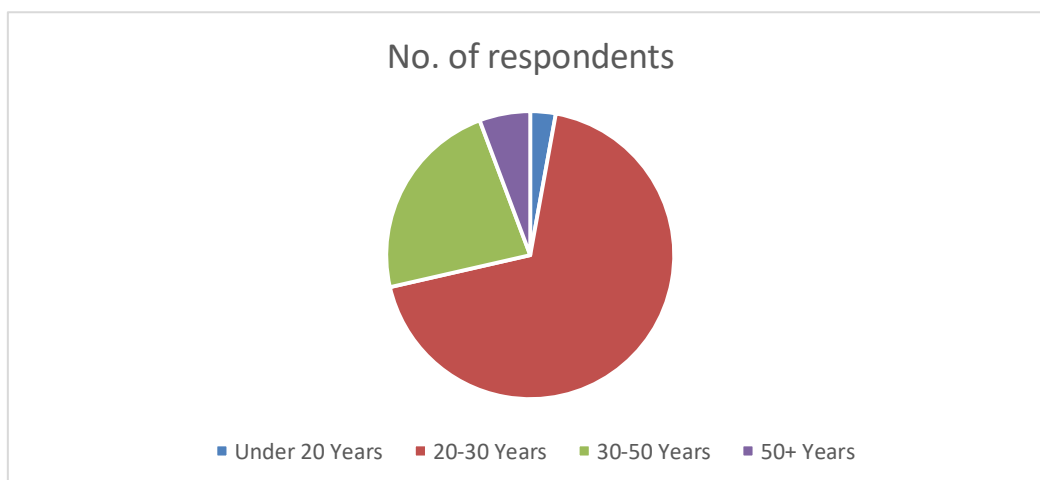

- Out of the 150 Survey Respondents, 14 are Under 20 Years. (9.3%)
- Out of the 150 Survey Respondents, 96 are from 20-30 age group. (64%)
- Out of the 150 Survey Respondents, 32 are from 30-50 age group. (21.3.8%)
- Out of the 150 Survey Respondents, 8 are above 50 years of age. (5.3%)
- Most of Survey Respondents are from the age group 20-30 as we wanted to study the Pattern and mindset of Next generation.

Place of residence

Place	No. of respondents
Tear 1	40
Tear 2	75
Tear 3	23
Urban Town	12

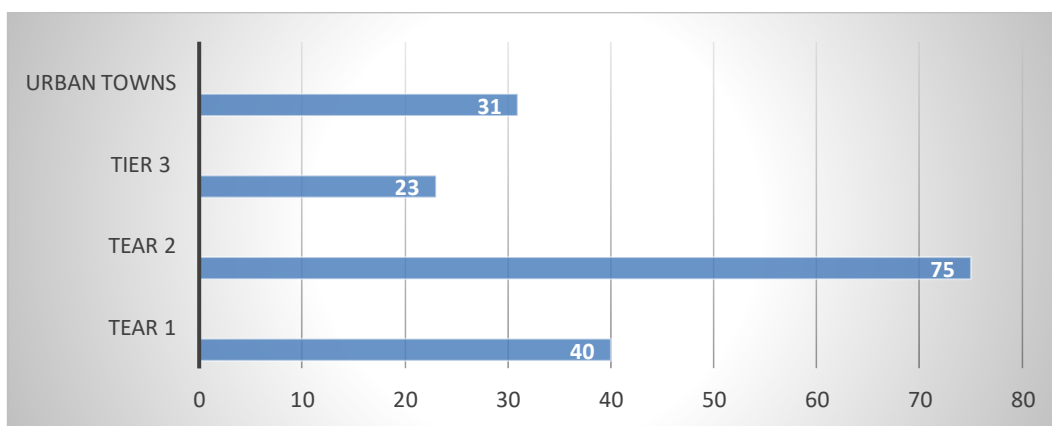

- Out of the 150 Survey Respondents, 40 are from tier 1.
- Out of the 150 Survey Respondents, 75 are from tier 2.
- Out of the 150 Survey Respondents, 23 are from tier 3.
- Out of the 150 Survey Respondents, 12 are from urban towns.

Profession

Profession	No. of respondents
Trader and investors	2
Service and Job	80
Businessman and self employed	42
Retired and not working	6
General Public	20

- Out of the 150 Survey Respondents, 2 lies in “Trader and investors category” (1.3%)
- Out of the 150 Survey Respondents, 80 lies in “Service and Job” category (53.3%)
- Out of the 150 Survey Respondents, 42 lies in “Businessman and self employed” category (28%)
- Out of the 150 Survey Respondents, 6 lies in “Retired and not working category” (4%)
- Out of the 150 Survey Respondents, 20 lies in “General public Category” category (13.3%)

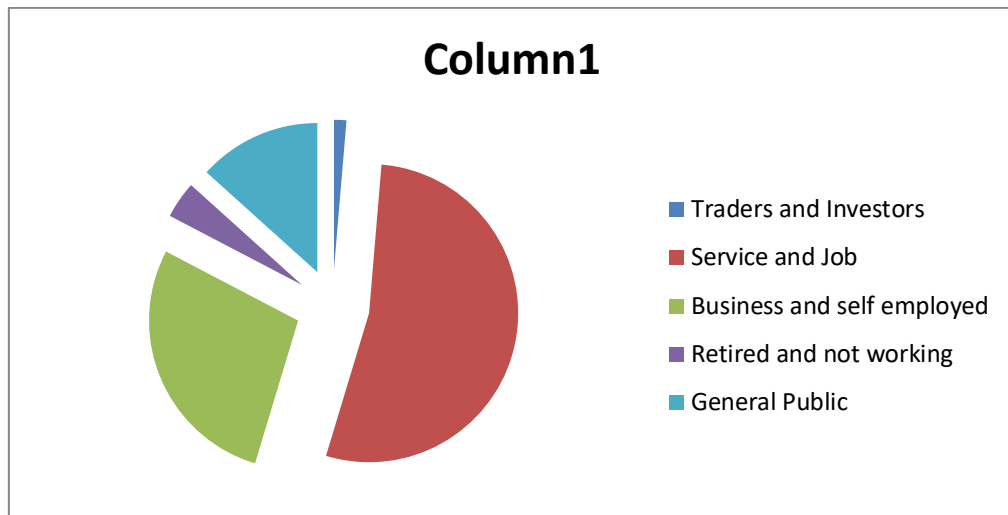

Investing your saving?

Answer	No. of respondents
Yes	96
No	54
Total Row	150

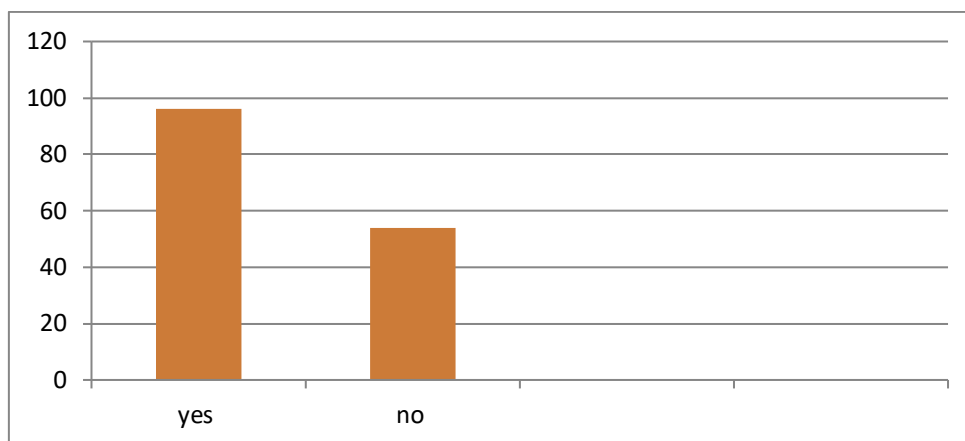

Most preferred choice for investment

Choices	No. of respondents
Mutual Funds And Investment schemes	16
Stock Market	3
Saving Account And Fixed Deposit	81
Bonds and debenture	21
Others	29

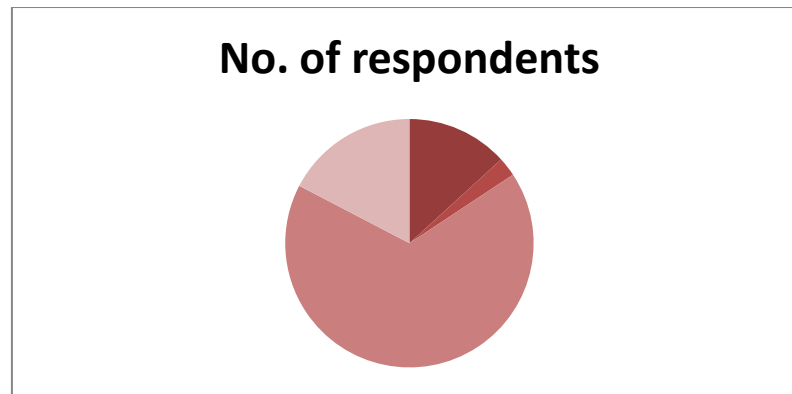

- Out of the 150 Survey Respondents, 16 responded mutual fund and investment scheme (10.6%)
- Out of the 150 Survey Respondents, 3 responded stock market (2%)
- Out of the 150 Survey Respondents, 81 for banking and fixed deposits (54%)
- Out of the 150 Survey Respondents, 21 responded bonds and debenture (1.4%)
- Out of the 150 Survey Respondents, 29 responded others (19.3%)

Knowledge of financial market

Knowledge	No. of respondents	Percentage of total
High	29	19.3%
Moderate	43	28.6%
Less	32	21.3%
No	46	30.6%



Conclusion:-The objective of this study is to gain a clearer understanding of why people in India are afraid to invest in stock market with following conclusion and limitations.

- Most of the people who live in tier 2 and tier 1 cities knew about the concept of stock market and how it affect their pay scale and business. Most People from tier 3 cities don't know about that.
- Most of the people of tier 2 and tier 3 cited all the reasons for not investing in stock market.

- More than 80% of people in these cities invest in banking channels such as FDs or other. Most of the conservative Indians are not willing to take a risk on their hard earned money and considers 4% return from the savings account as safe.
- Indian investors often cite a lack of understanding, financial risk, or other reasons for not investing their money in the stock market. Other short-term investors enter stock trading to earn a “quick buck” – and also exit the market forever after a bad experience.
- Research shows that most of the people agreed that regulations and rules are not much clear and not so easily understandable. Most people agreed that either these rules should be stated in clear ways or new ways to introduce regulations should be adapted. An expert also told that these rules and regulations make the trading harder than before and is the reason attracting less people in trading.
- Very few respondents (only those who trades or invests) said that stock broker exceed expectations, not fulfill all expectations, and switched to many brokers.
- The Indian stock market has had its share of past financial scams such as those involving Harshad Mehta and Ketan Parekh – that resulted in many stock market investors losing their money. Some of the recent scams include the NiravModi scam and the Satyam Computers scam.
- Most Indian investors lack a basic knowledge about the way stocks markets function. Investors believe that the stock market is an avenue for turning “quick profits.” As a result, they lack the necessary patience and end up buying – or even selling – stocks in quick time.
- Most Indians prefer to invest into “safer” instruments that provide low to modest returns – as compared to stock markets that are deemed as “risky” and considered suitable only for wealthy investors. In India, investing or trading in the stock market is perceived as gambling.
- “21 din me paisa double” whenever we talk about the stock market, people have unrealistic expectations of getting your money 100 times in stock.
- A common villager doesn’t know how to earn from stocks and doesn’t understand the power of compounding. A local retail shop owner does not know what is a demat and trading account. An old small town electrician hasn’t ever met an investor or trader in his entire life.
- “*I don’t have time*” – a common statement among the 9-to-5 working people in India, unwilling to take charge of their financial future.
- SEBI, the government, market participants, has to come a long way forward, create awareness, and win trust among people so that new investors join the stock market.
- Most of the people said after covid crisis Indian Stock market will move in positive trend, and Regulatory authorities are strongly active and keep vigilance on activity. Also Government and controlling authorities are providing continues support for growth, and taking steps towards that such as ease of doing business.
- Elders in India like to guide and motivate their young ones about investing money. However, they are also unable to comprehend the stock markets and, hence, are cautious about investing there. According to them, it is not a safe place to invest one’s hard-earned money. This keeps most young investors away from the stock markets.
- Indians thing stock market is a risky sector and people don't want to take risk, that’s why most of people investing in stock market have only invested less than 20 % of their investment capitals

- The average person's view on staying away from stocks is because the equity markets have not been able to guarantee the same level of trust that other forms of investment provide. Moreover, financial illiteracy prompts investors to prefer traditional methods of investment that give sure shot returns.

Reference:-

1. One Up On Wall Street – Peter Lynch
2. Bulls, Bears and Other Beasts – Santosh Nair
3. Financial management. - By I M Pandey 9th edition, Vikas Publishing House Pvt Limited.
4. Financial Management. - By Dr. P.N. Reddy and prof. H.R. Appanniah Himalaya Publishing House
5. Adekanye .F. (1987). Banks and Nigerian Economy. Nigeria Institute of Bankers Publication.
6. Agada, Simeon and Oliakah, Chibisi (1993). Distressed Banks Face Huge Withdrawals, Business Times, Vol. 18 No. 24, June 14, 1993.
7. Sebi database , Nse database
8. Everything You Wanted to Know About Stock Market Investing-CNBC TV 18

THE IMPACT OF E- PHARMACEUTICAL INDUSTRY IN INDIA

AUTHOR'S NAME: PROF. RAVI AHUJA

Research Scholar of Shri J.J.T. University

E-mail Address:- ravi_ahuja18@yahoo.com

Mobile Number: 9860880615

Abstract:-The marketing environment of India is developing rapidly, since the demonetization our country has started using the online payment options increasingly with various payment applications such as Paytm, google pay etc and this has waved a green signal for many industries to go for online business and as today online business offers almost everything including medicines. Under the e-pharmacies format, patients fill out their prescriptions online and get medicines delivered to their doorsteps. The global e-pharmacy market, estimated at \$69.7 billion in 2019, is expected to grow 17 per cent y-o-y to \$244 billion in 2027.

India's share in the global market is comparatively small. At \$9.3 billion in 2019, it is expected to increase at a CAGR of 18 per cent to \$18 billion by 2023. In 2020, Covid 19 has pushed many consumers towards buying their medicines online. A report also shows that over 60 to 70% of the medicines that are ordered through e-pharma platforms are from chronic patients as it more affordable and accessible for them. The growth of e-pharmacy in India is evident due to positive experience coupled with stronger adoption among low-income households.

Keywords:- E-commerce, e-pharma, applications, India.

Introduction:-Nowadays, many online industries are growing as people in the country are adapting to e-commerce rapidly with mobile first consumer behavior and improved digital payments infrastructure. In developed countries of North America and Europe, e-pharmacy is a flourishing market and is also structured, where the medicines are prescribed by doctors and tracked through barcoding to ensure systematic supply.

In India however, we have over eight lakh pharmacies, with pharmacies available every few kilometers. The e-pharmacies and healthcare companies have only recently grown in India because of Covid 19, improved Internet reach and smartphone penetration. The Indian e-pharmacy industry is some of well-known names in the market are Netmeds, EasyMedico and MedLife.

They are many startups that have also come up in the industry such as 1mg, Practo and Myra, even big retail stores like Apollo pharmacy have introduced their e-pharmacy segment.

In Indian pharmaceutical market is the third largest in terms of volume and 13th largest in terms of value. According to EY, the online pharmacy market in India is estimated to reach \$2.7 billion by 2023 from \$360 million which it is currently at.

In India, the retail pharma market is divided into 3 broad segments which are generic drugs, over the counter (OTC) drugs and patented products. Some of the country's largest conglomerates and multinational e-commerce companies are looking to invest and get a foothold in this sector. For example Amazon has recently invested over \$100 million in the largest Indian pharmacy chain Apollo Pharmacy.

In 2020, Reliance Retail invested Rs 620 crore to get a majority stake in Netmeds which is a Chennai based startup. Tata group also acquired a major stake in 1mg, while LGT Group and CDPQ the Canadian pension fund acquired Medlife in 2020. Even Pharmeasy is backed by the Singapore Temasek Holdings along with TPG a private equity firm from US.

Aims and objectives

1. To understand the growing concept of E-pharmacy
2. To examine the drivers of E-pharmacy
3. To analyze digital marketing strategies for the pharma industry

Research Methodology:-The study presents the Impact of E- Pharmaceutical Industry in India -. The research is completely based on secondary data which is collected through the Published sources, Magazines, Journals, Newspapers, Books and Internet Sources

Limitations:

1. The research study has limitation of time.
2. The study is generalized and indicative.
3. The analysed data is limited

Findings:

The market in India, is highly unstructured and fragmented, with over eight lakh pharmacies. Urban consumers have access to retail pharmacies every few kilometres. While the density is much less in rural areas, most villages have a friendly neighbourhood chemist shop. Amid relatively easy access to medicines and chemists physically, therefore, the need for online services is not that strong.

Several factors, however, could boost growth in the online pharmacy segment.

Drivers for e-pharmacy

- Increasing internet penetration – Internet penetration has grown at a rapid pace in India due to the availability of smartphones at affordable prices and deployment of 4G. With the Digital India Program underway, the number of internet users is set to reach approximately 600 Mn by 2025.
- Increasing preference for online shopping – Online shopping has gained a lot of popularity due to the pandemic. The convenience of getting products delivered at home is increasingly driving people to explore it for new categories, which was not the trend before. Online shopping for essentials and medicines is growing at a fast pace.
- Government support – The Jan Aushadhi Program is an essential part of the government's initiative to ensure the general population in the country has access to quality and affordable medicines. This, coupled with the Digital India Program, will allow Jan Aushadhi stores to be accessed through an application on mobile phones, which would benefit consumers significantly.
- Growing awareness of counterfeit drugs – The highly advanced and stringent tracking mechanism under e-pharmacy eliminates middlemen and the risk of counterfeit and sub-standard drugs.

Market scenario

The Indian e-pharmacy industry is still in its nascent stages. Some of the well-known names in the market are Netmeds, EasyMedico and MedLife. The segment is dotted with startups such as 1mg, Practo, and Myra. Even traditional chemists such as Apollo Pharmacy have introduced their e-pharmacy segment. Promising growth prospects in online pharmacy have attracted some big names such as Amazon and Reliance Retail. In August 2020, Reliance Retail acquired a majority stake in startup Netmeds. Pharm Easy also took a step toward consolidation by merging with Medlife. E-commerce giant Amazon too has launched online drug delivery services. The National Digital Health Mission (NDHM), aimed at improving the country's digital health ecosystem, will also boost growth in the online pharmacy segment.

Challenges

- Need for technical infrastructure – E-pharmacy needs a strong technical infrastructure to be successful. Even though Smartphone and internet penetration rates are increasing, the rural population remains largely out of reach and unaware. Government initiatives to expand online payment mechanisms and banks across the country are positive but more programs are required to ensure the on boarding of rural population on the e-commerce bandwagon.
- Poor connectivity in rural areas – Rural areas need a robust technological infrastructure for proper availability of online services. Besides, there is a substantial gap in terms of knowledge or awareness, for instance of smart devices. Internet connectivity is still missing in remote villages in the country.
- Need for regulations – The e-pharmacy space is largely unregulated, indicating scope for fraud and, therefore, lack of trust. Sale of drugs online should be regularized and monitored as the health of people is involved. The regulations should address all legitimate concerns and loopholes. Currently e-pharmacies register with the Drugs and Cosmetics Act, which is riddled with ambiguities and lacks a clear definition of over the counter (OTC) drugs. A clear set of regulations specifically for e-pharmacy must be implemented at the earliest.
- Requirement of emergency medicines – Online pharmacy can never take over the traditional setup, given the challenges associated with the supply of medicines in large quantities in case of emergencies. Hence, it is always perceived as an option for planned purchases only. The online e-pharmacy deliveries might not be able to meet the immediate need for medication and hence will still have to compete with traditional pharmacies which have shorter lead times from ordering to delivery.

Digital Marketing Strategies for the Pharma Industry

Digital has already transformed the pharma and healthcare industry in many ways such as greater levels of transparency, patient communication and drug development. In addition, due to its unrivalled cost-effectiveness, digital marketing strategies offer a variety of meaningful ways to connect and treat prospective clients and customers. In this article, we explore the key trends and tactics that will help marketers in the pharma industry to use digital marketing to promote, engage and grow.

1) Value-driven content creation

One of the most significant transformations seen by digital's influence on the pharma industry is the fact that pharmaceutical companies are no longer the sole gatekeepers or providers of the information surrounding their treatments or products.

Through online communities, mobile applications and a wealth of web content, people now have wide access to a range of pharma-based insights. By creating targeted, value-driven branded content that offers prospective or current patients insight into relevant information, you can grow your audience, significantly.

By providing answers to common patient pain points in an inspiring, engaging way alongside demonstrating transparency, you will grow your audience while fostering trust and positioning your brand as a thought-leader.

As an international healthcare brand, Johnson & Johnson are renowned for their wealth of inspiring content marketing initiatives but of all its campaigns, its 'Care Inspires Care' campaign is perhaps the most inspiring.

Boasting the perfect mix of value-driven, blog content, emotive messaging, social media posts, and eye-grabbing visuals, this particular campaign honed in on the importance of caring for one another. By prompting people to share their random acts of care through Facebook and supporting the campaign with a host of share-worthy content, the brand encouraged a total of 26 million acts of care - and counting.

2) Augmented & Virtual Reality

By 2022, the consumer VR software market is expected to grow to a worth of \$16.3 billion.

As VR and AR technology becomes an increasingly integrated part of our everyday lives, pharmaceutical companies can use this immersive technology to break down walls between its business and clients, partners, patients or consumers.

Despite AR and VR adoption in the pharma industry is in its infancy, some companies are already using immersive apps and tactics. These technologies not only place people at the heart of the business but can offer information and care through virtual clinics and product demonstrations.

To help people empathize with friends or loved ones that suffer from migraines while helping to promote its products and research, GlaxoSmithKline brand, Excedrin, developed a VR-driven campaign named, The Migraine Experience. Using a VR headset, migraine sufferers were able to program their specific symptoms (including blind spots, auras and sensitivity to light) before handing it over to their loved one so they could experience the traumas for themselves, filming the results to create video content.

3) Influencers

70% of millennials are influenced by the recommendations of their peers while 90% of 18 to 24-year-olds trust medical information acquired through social media while one-third of the U.S adults search online to understand a medical condition. So, there's great opportunity for pharma brands that work with respected industry influencers and thought-leaders.

Recommendations and Suggestions

E-pharmacies need to be aligned with the specific dynamics of the Indian market. Innovative ideas can be synergized in existing business models by companies. There are multiple ways for an e-pharmacy to become more relevant to the Indian consumer.

1)E-pharmacies can bring apt solutions for those suffering from chronic and long-term ailments. The patients can order one time and fill in details for scheduled delivery in future, eliminating the need to reorder each time. This system will also help e-pharmacies to monitor and ensure that the medication reaches the consumer before the previous dose is over.

2)Making consumers aware of the convenience could also help in building credibility and consumer base. Online pharmacies can develop strong logistics support to ensure delivery of medicines within a six-hour timeframe to take care of emergency needs while passing on cost benefits through discounts. Also, sharing information on drugs, counter-indications, precautionary measures to be taken for certain dosages, and cheaper generic substitutes would help the consumer make informed decisions.

There is significant untapped potential in the sector. To tap it effectively, India needs to make the value chain more efficient, define regulations, have right processes in place and ensure adherence to best practices.

Conclusion:-People today are highly busy and spend the most of their time on mobile phones, laptops or digital devices. Digital marketing is important in the pharmaceutical sector, according to the available research data. Digital commercialization allows the industries to grow rapidly. It has become a strong marketing cornerstone and has encouraged and made campaign strategies even simpler. Only a handful of digital marketing methods are popular, and the others are in the process. Although there are many challenges for the pharma industry as India has good retail market but with various strategies and easy online platforms the industry is growing and offering affordability and comfort to its population.

References:

- 1.https://www.researchgate.net/publication/339792976_DIGITAL_MARKETING_IN_PHARMACEUTICAL_SECTOR
- 2.<https://digitalmarketinginstitute.com/blog/5-digital-marketing-strategies-for-the-pharma-industry-corporate>
- 3.<https://economictimes.indiatimes.com/tech/startups/2020-year-in-review-how-covid-19-is-reshaping-online-pharmacy-in-india/articleshow/80010076.cms?from=mdr>
- 4.<https://www.expresspharma.in/e-commerce-will-e-pharmacies-become-the-norm/>
- 5.<https://www.isb.edu/en/research-thought-leadership/research-centres-institutes/centre-for-learning-and-management-practice/management-rethink/ManagementReThinkVol2Issue2/can-digital-health-startups-bolster-a-creaking-healthcare-system.html>
- 6.[rethink/ManagementReThinkVol2Issue2/can-digital-health-startups-bolster-a-creaking-healthcare-system.html](https://www.isb.edu/en/research-thought-leadership/research-centres-institutes/centre-for-learning-and-management-practice/management-rethink/ManagementReThinkVol2Issue2/can-digital-health-startups-bolster-a-creaking-healthcare-system.html)

A STUDY OF FOREIGN DIRECT INVESTMENT IN INDIAN PHARMACEUTICAL SECTOR

RESEARCH SCHOLAR - ATUL S PANDEY

Department of Management (BMS / BAF)

E-mail Id: atulpandey127@gmail.com

Mobile no: 7977950485

Abstract:- India is a prominent and rapidly growing presence in global pharmaceuticals. It is the largest provider of generic medicines globally, occupying a 20% share in global supply by volume, and also supplies 62% of global demand for vaccines. What is clear is that the time is right for all stakeholders, from government, academia and industry to invest in this future, to achieve the Indian government's target of becoming a \$5 trillion economy by 2025. However, to do so, the pharma industry will need to take some well- thought-out risks, embrace the right opportunities and, importantly, fire on all cylinders! One solution to reduce risks is to optimise the potential of digital technologies to help Indian pharma companies improve the efficiency and effectiveness of their drug development process, from discovery, through clinical trials to regulatory approval, making the whole process faster and cheaper than what is currently possible

Key Words:- FDI, India Pharmaceutical Sector, Pharma Industry, FDI Inflows, Nifty Pharma

I. INTRODUCTION

India is recognized as global hub for cost effective generic medicines, which is vital in protecting the right to health in developing and underdeveloped countries. FDI is necessary to bring newer and safer technology in India. However, present policies on FDI in India need a relook. Government in India should also make sure that excessive foreign investment does not hamper the local business and companies (especially one involved in Generic medicine), market and the pricing of medicines in India. The startup policies of current NDA government, Pharma Vision 2020 and its proper implementation are important in this regard. The FDI in pharma sector will serve its purpose if suggestions mentioned herein above are implemented properly. Pharmaceutical industry India plays a very crucial role in implementing the welfare state of the people. The economic growth of the industry along with the availability of generic goods and healthy competition is the need of the hour for India. After analyzing the pros and cons of the FDI in the Indian Pharmaceutical Industry, it is established that India needs adequate FDI and its spillovers for the growth of the industry. The government has remained active in formulating policies to ensure overall growth of the industry. From 2001 onwards 100% FDI in pharmaceutical Industry has been allowed This has benefitted the pharma sector. From 2006-10, as many as 6 top Indian Companies have been acquired by the MNCs. This has not resulted in price rise or limited supply of generic goods. India is a huge potential market for the MNCs with competent and cheap workforce. However the concerns relating to FDI in pharma sector remain. Though the statistics don't show them, they may surface over a period of time. For this purpose some control of government over the FDI in pharma sector was needed. The Central Government has notified that in cases of Brownfield investments in the pharmaceutical sector, FDI will be allowed through the FIPB approval path for a period of up to six months. In this period, the government will put in place the essential enabling mechanism for oversight by the competition commission of India. After six months, the oversight will be done by the

Competition Commission of India (CCI) entirely in accordance with the competition laws of the country. It seems that the current (FIPB) and the proposed (CCI) approval requirements may act as a speed breaker for potential foreign investors as they may have to show that their intention is not to collude or undertake predatory pricing or any such anti-competitive practice. If the government makes necessary amendments and CCI's jurisdiction is enhanced to include all prominent pharma acquisitions by MNCs, it will ensure competition in the pharma industry in a transparent manner. With regards to the public interest concern, the Government can come-up with alternative public policies like public procurement of generic goods and fixing the price of essential drugs. CCI, however remains a recently established institution. Its expertise is limited to the competition aspect of the industry. It remains untested, as of now. Government of India has taken a very optimistic decision to allow CCI to be the watchdog over all the mergers and 43 acquisitions in the pharma industry, but it must ensure that it brings about necessary amendments to the Competition Act 2002 and widen the scope of the commission.

II. OBJECTIVES

- To get the information about the foreign direct investment data
- To find out the effect of fdi and Nifty pharma index on pharma sector
- To analysis of top pharma companies in pharma sector
- To find out the growth and opportunities in pharmaceutical industry
- To analysis the challenge faced by the industry
- To analysis covid 19 impact

III. PROBLEM STATEMENT

Aitkin & Harrison (1999) argue that FDI can have negative effects on the domestic firms' productivity, which may be large enough to offset the positive impact from FDI. The so-called "market stealing effect" refers to when foreign firms enter a host economy and their technology advantages take over the domestic market shares. The MNCs' advantages draw demand away from the domestic firms' products; hence the domestic firms' productivity decreases. Examples of studies that show negative spillover effects are Aitkin & Harrison (1999) and Haddad & Harrison (1993)

Lack of capabilities in the innovation space The report states that the government needs to invest in research initiatives and talent in order to grow India's innovation.

Quality compliance scrutiny India has experienced the highest number of FDA inspections since 2009; therefore, continued investment into upgrading quality standards will divert capital away from other areas of development and distract from growth, says the alliance.

A lack of a stable pricing and policy environment The challenge posed by frequent and unexpected changes to domestic pricing policy in India have created an uncertain environment for investments and innovations.

I. LITERATURE REVIEW

Tamma Koti Reddy (2013) studied on Foreign Direct Investments in Indian Pharmaceutical Industry they stated that, Although India has substantially liberalized its foreign investment policy, the foreign direct investment inflows had been much below the targets until recently. Market leaders in pharma industry should raise their expenditure towards Research & Development. Academic collaboration would help the pharma industry with regard to Drug development.

Dr. Nishikant C. Dhande, Prof. Anshuman Vijay Magar studied that A Study of Foreign Direct Investment in Indian Pharmaceutical Industry, they implement that The foreign direct investment route is the fastest, safest and most effective mode of bringing in the most modern technology in India. India is hub of Generics, which will attract huge inflow of FDI in next few years.

Ronny Thomas, K. Narayanan and Vinish Kathuria studied that FDI and R & D in the Pharmaceutical Sector in India, he stated that Expenditure on research and development (R&D) is identified as an important source for promoting innovation and technological learning in developed as well as developing countries. Further, the scope of investment in R&D has increased with the progressive liberalization and increased flow of cross-border investment.

Annika Bergman (2006) studied on FDI and spillover effects in the Indian pharmaceutical industry. This is a study of FDI and spillover effects in the pharmaceutical industry in India. Horizontal productivity spillover effects of MNCs, to the domestic Indian pharmaceutical firms, are analyzed and potential transmission channels through which spillover effects might occur are studied. The pharmaceutical industry is severely technological and capital intensive and India is one of very few developing countries that have a comparative advantage in the industry.

Dr. Gulshan Akhtar study on Problem and Prospect of FDI inflows in Indian Pharmaceutical Industry, As FDI comes with financial and managerial resources, access to large markets, technical assistance and strategic assets, such as brand name, which give the host firms domestic and international comparative advantages. It has been noticed that there has been ample opportunity for the concentration of FDI in the sector particularly export and profitability of the sector.

Reji K. Joseph & K.V.K. Ranganathan Study on Trends in Foreign Investment in Healthcare Sector of India This indicates that the hospitals and clinics in India have been using private equity investments which only look for substantial profits and have no long term commitment for their expansion. This raises serious concerns for public at large in a country like India where the public investment in healthcare is low and out of pocket spending on healthcare is pushing millions of people into poverty.

Dr. Vikarant sopan Yadav he studies about an analytical study of foreign direct investment in pharma sector of India. However, present policies on FDI in India need a relook. Government in India should also make sure that excessive foreign investment does not hamper the local business and companies (especially one involved in Generic medicine), market and the pricing of medicines in India. The startup policies of current NDA government, Pharma Vision 2020 and its proper implementation are important in this regard.

Harshvardhan Jain & Mayank Rautela (2018) research on FDI in Indian Pharmaceutical Sector But policy should be such to minimize or even remove all objections or disadvantages from FDI inflows into a country. It is also needed because 100% FDI is allowed in this sector which “poses direct threat to the entire health and IPR framework of our country in terms of access and affordability of medicines, domination and elbowing out of our pharmaceutical industry, undue demand and pressure on TRIPS arrangements”¹⁷ as per parliament committee report.

RESEARCH METHODOLOGY

Source/s of Data

Secondary source we collect data from Internet searches or libraries, for extensive research survey, various published sources like printed books, online journals, research thesis, dissertations and various online websites were used like RBI, Make In India, Pharma industry, etc

Data Collection Method

Existing data Research Journals – like Economic times, Business Standard, Financial Chronicle, Financial Express newspapers, Outlook Money, Money Today, Wealth Insight magazines, research journals are intended for an academic or technical audience, not general readers. A journal is a scholarly publication containing articles written by researchers, professors, and other experts.

Date Collection Instrument

Archival documents and government sources. Gathering and using data contained in website articles tools which help in study depth of pharmaceutical industry. Research papers, journals, articles, financial newspaper, bulletins, reference book, research report etc

Sample Design

In below Graph 1.2 all data which mentioned in graph are taken from RBI site, in which there are top 8 Different sector like Service, ITSector, Telecommunications, Trading, Constructions Development, Automobile, Chemicals, Drugs & Pharmasutical Sector etc. Which Explained about how FDI inflown Invested into different sector also intoPharma sector.

IV. LIMITATIONS

- Acquisition of domestic firms in the name of FDI may result into domination of foreign firms and it make the domestic firms into mere manufacturing units.
- Foreign Direct Investments are one of the reasons for exchange crisis at times. With inflation contributed by them, exports have dwindled resulting in heavy fall in the value of domestic currency.

Inflation in the Economy: The presence of FDIs has also contributed to the inflation in the country. They spend lot of money on advertisement and on consumer

UNDERSTANDING E-CRM AND TRENDS IN 2020

Name: Mr. Adusupalle Muni Raju

Reg. No: 261117081

Research Scholar

Shri Jagdish Prasad Jhabarmal Tibrewala University

Email Id: muniraju.a87@gmail.com

Mob: 9923216109

Abstract:- The aim of this research paper is to provide information about E-CRM. Customer is an important aspect for organizations and their business. It is about interacting with customers using digital tools and techniques so as to retain them. This retaining will result in increase in business for the organizations.

The author wishes to likewise feature what are E-CRM and the trends visible in near future within such E-CRM domain in view of ongoing technological developments across the globe. This exploration paper gives a few insights as provided by some of the CRM service providers on what could be the trends those are likely to be adopted by CRM systems.

Keywords:- Customer Relationship Management (CRM); Electronic Customer Relationship Management (E-CRM); E-Commerce; Customer satisfaction

Objective

The aim of this study is to provide information about E-CRM. The author wishes to likewise feature what are E-CRM and the trends visible in near future within such E-CRM domain in view of ongoing technological developments across the globe.

Methodology

This paper is based on secondary data gathered by the author. The news articles which are related to customer relationship management or electronic customer relationship management has been reviewed for this research paper.

1. INTRODUCTION

Customer Relationship Management (CRM)

Technology had bought several ways to do business in different ways ensuring the profitability. CRM is one way of doing it. This is mainly because for any organization, customer brings business and in turn revenue. CRM with its unique and structured frameworks allows seamless interaction. It also facilitates your sales staff to carry out any promotional campaigns with ease and in cost effective manner (Saini and Kumar, 2015) [1].

What is CRM?

CRM is all about organizing and monitoring of the customers. It is characterized as the standards and practices behind connecting with clients. CRM programming is, at its easiest, a database of clients and potential clients. At its most, it is propelled programming to enable your deals to group including making the inquiry to showcasing effort dissemination and an enormous piece of your business enablement procedure (Investopedia) [2].

2. LITERATURE REVIEW

There is growing use and increasing popularity of the internet across the globe. This has resulted into electronic or online version of CRM (as E-CRM) provided by the organizations to their clients. This has become mainstay of their business promotion and advertising strategies. Particularly, it is used as marketing tool (by the organizations) and broadly being used during relationship-building stage (Lam et al., 2013) [3].

E-CRM has grown progressively and also received good acceptance. This is mainly because it empowers organizations to actualize intuitive, customized and significant correspondence with clients through electronic and conventional channels (Milovic, 2012) [4].

E-CRM is the most recent procedure organizations are utilizing to increment and upgrade their showcasing aptitudes and capacities (Alhaiou et al., 2009) [5]. It is mixture of use of software application, programming, equipment, application and the executives responsibility (Dyche, 2001) [6], which is looking at pulling in and keeping financially important clients and disposing of less beneficial ones (Romano and Fjermestad, 2001) [7], building steadfastness and benefit, expanded consumer loyalty, improved procedures and lower costs, better knowledge and dynamic of the association (Winer, 2001) [8].

Web and email as a piece of electronic and intelligent media are assuming critical job in functioning and implantation of CRM and bolster compelling modified data between the association and clients (Kennedy, 2006) [10].

E-CRM has become a prerequisite for endurance nowadays, an upper hand as well as permits clients to get to organization from an ever increasing number of spots, since the web passageways are expanding step by step. Utilizing innovation to upgrade communications with the end users, organizations can make a clean perspective on clients to gain from past connections to streamline future ones (Chen and Popovich, 2003) [11].

3. EMPIRICAL DATA

The author would like to present empirical data in the form of findings of some studies from CRM service providers that indicate that CRM is going to be mainstay for the organizations in the years to come.

3.1 Top CRM Trends to look for in 2020 (AgileCRM) [12]

As indicated by the said investigation by Agile CRM, here are a portion of the CRM inclines in 2020. They are:

3.1.1 Customer Experience :

If the associations need to catch everyone's eye of items or administrations like what they offer, they'll need to concentrate more on client experience. Concentrating on the collaboration between their image and their clients and guaranteeing that the associations are leaving them with a decent impression will go far. With successful CRM programming that houses the entirety of their client collaborations, they'll have the option to begin where the clients left off every single time you speak with them.

3.1.2 Automation:

Automation of sales process is nothing but making them more systematic and make them easily accessible by the sales personnel. This will facilitate salespeople carry out their responsibility quicker, more precisely, and all the more viably. Upgraded CRM devices can offer manners by which to computerize forms and abbreviate the business cycle and is certainly one of the CRM slants in 2020. Computerization can help with assignments, for example, information section, client association logging, customized email arrangements, and the sky is the limit from there. Some CRMs offer showcasing mechanization includes also, taking into account more to complete by less assets in less time.

3.1.3 Artificial Intelligence (Forbes) [13]:

Artificial insight (AI) is starting to assume a key job in numerous parts of deals and promoting, including inside CRM programming. Their declaration is that AI is playing all the more an indispensable job in deals by offering the accompanying:

- Easier information storage and recovery.
- Sentiment investigation capacities.
- Better information respectability.
- Predictive lead scoring.
- Personalized arrangements / proposals.

3.1.4 Mobile:

If the marketing personnel are interacting face to face with their customers then it may result in sales. Just working on computers will not generate any revenues (to the organization). With growing penetration of smartphones, mobile version of the CRM may be in vogue after 2020. Later it may become a prerequisite in the event that you need your personnel to utilize your CRM even when they are moving in the marketplace.

3.1.5 Social Media

Social media is buzzword today and everybody uses that. No wonder that it is has become an essential part of promotion and distribution strategy (of the organizations) today. With their ability to create and manage different types of mobile-based promotional activities and ability to fetch the sales enquiries directly from the CRM, organizations will use mobile based CRM.

3.1.6 Easy User Interface

If the organization is not able to interact with their customers then it may not generate revenues and may not be making proper utilization of the said CRM. To avoid this, the CRM must ensure an easy user interface that is able to interact with customers effectively. For organizations, when their people see that it is simple to use and operate, they will quickly accept it and start using it.

3.1.7 Exploring Multiple Avenues for Marketing

It is quite obvious that organizations will use numerous ways for marketing their products and services. With this it may be possible to draw prospective customers and maintain the sequence of getting revenues by using these multiple ways. For instance, if the one way of purchasing is not used by the customer, then (the CRM) the customer may be provided with another way to continue with this buying activity. The information pertaining to various users that organizations may gather would be helpful for them in understanding and learning of the experiences (of using multiple avenues for marketing) in an effective manner.

3.2 Critical Trends in 2020 for CRM (SelectHub) [14]

According to the said study by SelectHub, here are some of the critical trends identified by their research study. The same are reproduced herewith.

3.2.1 The Age of Customer Experience (Salesforce) [15]

Today economic uncertainties and changes the business cycle. SelectHub cites CRM as an opportunity for the organizations to grow their business activities. According to them it is about providing the unexpected experience (to the customer), when any purchasing activity is going to happen.

3.2.2 According to the another Sales force study:

- Most of the respondents (about 84%) take into account the experience as important as products or services.
- Nearly three fourth of the respondents say that a single surprise encounter will augment their outlook everywhere else.
- Nearly two third of the respondents are of the opinion that they will pay more to get the superior experience.

3.2.3 The Increasing Role Artificial Intelligence (AI)(Salesforce) [16] AI will have an increasing role, as indicated by one of the Sales force investigations. Respondents to the 2019 State of Marketing report provided their views and opinions in favour of growing use of AI. Typical functional areas encompassed by AI are:

- Differentiation of end users.
- Information clustering.

- Customized promotion and media buying.
- Personalization of the channel understanding.

3.2.4 Mobile CRM going to stay here (MarTech) [17]

Mobile based CRM will continue to entice the end users as they will offer variety of features such as:

- Strong security highlights.
- Intuitive interfaces.
- Applications that work across stages.

3.2.5 CRM will encompass social interaction within (Salesforce) [18]

With the scope of understanding of the customer getting wider and wider it may be a good thing to use social media tools to make that understanding more effectively understood by the organizations. This will allow communications at personal level and facilitate one-to-one marketing.

In this context, another Salesforce study cites customer learnings in B2B and B2C in 2019. It found two or three things important:

- Four out of each ten respondents said that they would be associated with a brand in particular on the off chance that they (the brand) could utilize their preferred social media.
- Nearly three fourth of the respondents thinks different kind of (social media) channels for various purposes and settings.

These discoveries point to the significance of consolidating social channels into CRM stages and techniques. From giving important information to offering social listening openings, social media tools and their usage within CRM will be inevitable.

3.2.6 CRM Software Will Become More User-Friendly(BlazeIt) [19]

According to David Dozer, CTO of Blaze IT LLC, the coming few years (for CRM) will bring about a “renaissance of simplicity, where the focus shifts back to making things easy and simple to use.” He mentions that “CRM systems have grown and evolved so much over the last decade that in some cases they now mimic ERP systems in some areas.”

3.2.7 CRMs is going together (Salesforce) [20]

Incorporation of the legacy systems as well as lending support to them may be considered essential ingredient of the CRM systems of the current generation. These systems are capable of storing existing transactions. With passing time, the systems are using increasing numbers of diverse resources (to gather and analyze the information). There is increment in number of information sources by such systems. Salesforce found out that organizations and CRMs utilized more number of information sources (from 12 in 2018 to 15 in 2020). Over and above that, seven of every ten organizations made use of information from secondary sources in 2018. That is about 20% growth as compared to 2017.

3.2.8 Channel-Less CRM(Forbes) [21]

This is a generally ongoing improvement yet one that Hyken accepts is the greatest open door pushing ahead for CRM clients and sellers. What's more, it applies not to how CRMs can help clients yet to how they can smooth out inside exercises. "At this moment, there are such a significant number of various ways you can speak with an organization," Hyken says. "You can utilize the telephone, email, content, informing applications or web-based social networking." The end result, Hyken clarifies, is to construct the innovation that empowers a client experience that is channel-less.

4. CONCLUSION

It may be concluding that the CRMs are here to stay so as to attract and retain the customers. The organizations must pay attention to the changes in the market and the product trends that

are conveyed by the customers. It's true that organizations can enhance their authenticity and credibility of their website with E-CRM.

5. REFERENCES

- 1.Saini Gurmeet Singh and Kumar Sushil (2015). The Effect of e-CRM on Customer Satisfaction: An Empirical Study of Online Shopping, *Journal of Management and Science*, Vol.5, No. 2, June'2015. [ISSN: 2249-1260, e-ISSN: 2250-1819].
- 2.Investopedia.Customer Relationship Management (CRM). Available from: https://www.investopedia.com/terms/c/customer_relation_management.asp. [Last accessed on 2020 March 3].
- 3.Lam, A., Cheung, R., & Lau, M. M. (2013). The Influence of Internet-Based Customer Relationship Management on Customer Loyalty. *Contemporary Management Research*, 9(4), 419-440. It is cited by (Saini and Kumar, 2015) [1].
- 5.Milović, B. (2012). Social Media and E-CRM as a Prerequisite for Hotel Success. *Management Information Systems*, 7(3), 26-31. It is cited by (Saini and Kumar, 2015) [1].
- 6.Alhaiou, T., Irani, Z., & Ali, M. (2009). The relationship between e-CRM implementation and e-loyalty at different adoption stages of transaction cycle : a conceptual framework and hypothesis. *European and Mediterranean Conference on Information Systems*. Izmir. It is cited by (Saini and Kumar, 2015) [1].
- 7.Dyche, J. (2001). *The CRM Handbook: A Business Guide to Customer Relationship Management*. Addison-Wesley Professional. It is cited by (Saini and Kumar, 2015) [1].
- 8.Romano, N. C., & Fjermestad, J. (2001). Electronic Commerce Customer Relationship Management: An Assessment of Research. *International Journal of Electronic Commerce*, 6(2), 61-113. It is cited by (Saini and Kumar, 2015) [1].
- 9.Winer, R. S. (2001). A framework for customer relationship management. *California Management Review*, 43(4), pp. 89-105. It is cited by (Saini and Kumar, 2015) [1].
- 10.Sheth, J. N., Sisodia, R. N., & Sharma, A. (2000). Antecedents and consequences of the growth of customer-centric marketing. *Journal of the Academy of Marketing science*, 28(Winter), pp, 55-66. It is cited by (Saini and Kumar, 2015) [1].
- 11.Kennedy, A. (2006). Electronic Customer Relationship Management (eCRM): Opportunities and Challenges in a Digital World. *Irish Management Review*, 18(1/2), pp. 58-68. It is cited by (Saini and Kumar, 2015) [1].
- 12.Chen, I. J., & Popovich, K. (2003). Understanding customer relationship management (CRM)People, process and technology. *Business Process Management Journal*, 9(5), pg. 672-688. It is cited by (Saini and Kumar, 2015) [1].
- 13.AgileCRM - Top CRM Trends in 2020. Available from: <https://www.agilecrm.com/blog/top-crm-trends-in-2020/>. [Last accessed on 2020 March 3].
- 14.Forbes - Forbes explored five ways AI is transforming CRMs. Available from: <https://www.forbes.com/sites/falonfatemi/2019/08/10/5-ways-artificial-intelligence-istransforming-crms/#45a79d315354/>. (It is cited by AgileCRM [12]).
- 15.SelectHub - Seven Critical CRM Trends to Keep an Eye on for 2020. Available from: <https://www.selecthub.com/customer-relationship-management/crm-trends/>. [Last accessed on 2020 March 3].
- 16.Salesforce Study. Available from: https://www.salesforce.com/form/conf/state-of-the-connected-customer-3rd-edition/?leadcreated=true&redirect=true&chapter=&DriverCampaignId=7010M000000ujR9QAI&player=&FormCampaignId=7010M000000ujR4QAI&videoId=&playlistId=&mcloudHandlingInstructions=&landing_page=%2Fform%2Fpdf%2Fstate-of-the-connected-customer-3rd-edition/. (It is cited by SelectHub [14]).Salesforce–2019State of Marketing

Report. Available from: <https://www.salesforce.com/form/conf/5th-state-of-marketing/>. (It is cited by SelectHub [14]).

17.MarTech - A 2018 report from MarTech Advisor. Available from: <https://www.martechadvisor.com/white-paper/crm/evaluate-your-crm-readiness-for-2020-and-beyond/>. (It is cited by SelectHub [14])

18.Salesforce Study on CRMs. Available from: <https://www.salesforce.com/blog/2019/06/customer-engagement-trends.html?ss-blog-nl>. (It is cited by SelectHub [14]).

19.BlazeIt – Simple CRM in vogue. Available from: <https://www.blazeitweb.com/>. (It is cited by SelectHub [14]).

20.Salesforce – CRM Increase in number of data sources used by marketers. Available from: <https://www.salesforce.com/form/conf/5th-state-of-marketing/>. (It is cited by SelectHub [14]).

21.Forbes – Channel-less CRMs. Available from: <https://www.forbes.com/sites/shephyken/2017/03/04/moving-from-omni-channel-to-a-channel-less-customer-experience/#36ddeb266295/>. (It is cited by SelectHub [14]).

COMMERCIAL CHALLENGES MANUFACTURING THROUGH LASER PROCESSING MANAGEMENT

Vaishali Deshmukh

ABSTRACT: - Even though technology for laser cutting of paper materials has existed for over 30 years, it seems that results of applications of this technology and possibilities of laser cutting systems are not easily available. The aim of this study was to analyze the feasibility of the complex geometry laser cutting of paper materials and to analyze the innovation challenges and potential of current laser cutting technologies offer. This research studied the potential and possible challenges in applying CO₂ laser cutting technology for cutting of paper materials in current supply chains trying to fulfill the changing needs of customer in respect of shape, fast response during rapid delivery cycle. The study is focused on examining and analyzing the different possibilities of laser cutting of paper material in application area of complex low volume geometry cutting. The goal of this case was to analyze the feasibility of the laser cutting from technical, quality and implementation points of view and to discuss availability of new business Opportunities.

KEYWORD:-Slaser cutting, paper material, cellulose, application, processing.

INTRODUCTION:- Is a technology that uses a laser cut materials, and is typically used for industrial manufacturing applications, but is also starting to be used by schools, small businesses, and hobbyists. Laser cutting works by directing the output of a high-power laser most commonly through optics. The [laser optics] and CNC (computer numerical control) are used to direct the material or the laser beam generated.

A commercial laser for cutting materials involved a motion control system to follow a CNC or G-code of the pattern to be cut onto the material. The focused laser beam is directed at the material, which then either melts, burns, vaporizes away, or is blown away by a jet of gas, leaving an edge with a high-quality surface finish. Industrial laser cutters are used to cut flat-sheet material as well as structural and piping materials.

In 1965, the first production laser cutting machine was used to drill holes in diamond dies. This machine was made by the Western Electric Engineering Research Center. In 1967, the British pioneered laser-assisted oxygen jet cutting for metals. In the early 1970s, this technology was put into production to cut titanium for aerospace applications. At the same time CO lasers were adapted to cut non-metals, such as textiles, because, at the time, CO lasers were not powerful enough to overcome the thermal conductivity of metals.

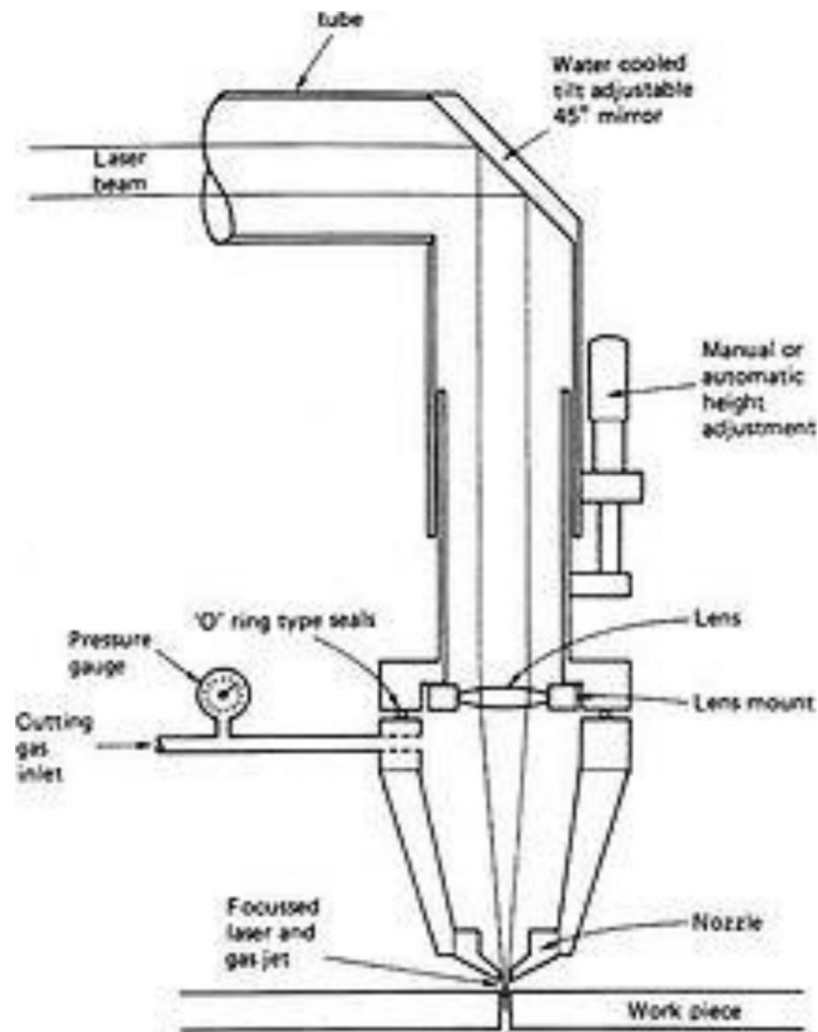

METHADODOLOGY:- Generation of the laser beam involves stimulating a lasing material by electrical discharges or lamps within a closed container. As the lasing material is stimulated, the beam is reflected internally by means of a partial mirror, until it achieves sufficient energy to escape as a stream of monochromatic coherent light. Mirrors or fiber optics are typically used to direct the coherent light to a lens, which focuses the light at the work zone.

The narrowest part of the focused beam is generally less than 0.0125 inches (0.32 mm) in diameter. Depending upon material thickness, kerf widths as small as 0.004 inches (0.10 mm) are possible. In order to be able to start cutting from somewhere other than the edge, a pierce is done before every cut. Piercing usually involves a high-power pulsed laser beam which slowly makes a hole in the material, taking around 5—15 seconds for 0.5-inch-thick (13 mm) stainless steel, for example.

The parallel rays of coherent light from the laser source often fall in the range between 0.06—0.08 inches (1.5—2.0 mm) in diameter. This beam is normally focused and intensified by a lens or a mirror to a very small spot of about 0.001 inches (0.025 mm) to create a very intense laser beam. In order to achieve the smoothest possible finish during contour cutting, the direction of beam polarization must be rotated as it goes around the periphery of a contoured workpiece. For sheet metal cutting, the focal length is usually 1.5—3 inches (38—76 mm).

Advantages of laser cutting over mechanical cutting include easier workholding and reduced contamination of workpiece (since there is no cutting edge which can become contaminated by the material or contaminate the material). Precision may be better, since the laser beam does not wear during the process. There is also a reduced chance of warping the material that is being cut, as laser systems have a small heat-affected zone. Some materials are also very difficult or impossible to cut by more traditional means.

Laser cutting for metals has the advantages over plasma cutting of being more precise and using less energy when cutting sheet metal; however, most industrial lasers cannot cut through the greater metal thickness that plasma can. Newer laser machines operating at higher power (6000 watts, as contrasted with early laser cutting machines' 1500 watt ratings) are approaching plasma machines in their ability to cut through thick materials, but the capital cost of such machines is much higher than that of plasma cutting machines capable of cutting thick materials like steel plate.



LESER PROCESSING EQUIPMENT

CHALLENGES

Laser cutting becomes less effective when material thickness increases. For instance, lasers may be ineffective for cutting carbon steel thicker than .4 inches. Laser cutting thickness limitations are determined by heat conductivity, surface reflection at 10.6 microns, the vaporization point of alloys, the types of alloys, surface tension of molten materials, and part geometry. As thickness increases, the likelihood of a blowout or thermal runaway also increases. By highly focusing its beam and reducing its spot size, the laser becomes a sharper cutting tool. For example, a laser's cutting ability increases significantly when the spot size is narrowed from even .004 to .01 1 inches in diameter. Ideally, the wavelength will allow 100 percent absorbability with the material. In many instances, the laser's ability to cut can be further improved by focussing the assist gas. The assist gas serves two purposes: to help in combustion, and to blow the debris or molten metal from the kerf.

Reference:-

1. Bromberg Joan (1991). The Laser in America 1950-1970, MIT press. p.202. ISBN978-0-262-02318-4.
2. Oberg, Erik, Jones Franklin Dr. Horton Holbrook L Ryffel, Henry H. (2004). Machinery Handbook (27th Ed). New York NY; Industrial Press Inc. ISBN978-0-8311-2700-8.
3. Todd, Robert Hri Allen, Dell K; Alting Leo (1994). Manufacturing Process Reference guide .

A Study of Patriarchy and Masculinity and its impact on the modern Indian Society

Divya Alok

Ph.D Scholar

Shri J.J.T.University

Dr. Tandon Kamal

Director Education

The Synthetic and Art Silk Mill's Research Association

Abstract:-This study examined patriarchy and masculinity and their effects on a large scale. The study focuses on the basics of patriarchy and masculinity and the realms that surround them. The basic concepts have been studied in the academic curriculum and also through parallel investigations. The study is based upon the research conducted through site surfing and article references. The main motive of the research is to get an exposure to the real world scenario and to apply the learnt theories in real life situations. The objectives of this study were to learn the concept of patriarchy and masculinity, understand whether patriarchy affects the executives personal and professional life, to explore the effects of masculinity on organizational/work relationship, to learn the laws that exist against the gender discriminations at workplace and to explore whether organizations are taking any steps eliminate patriarchy or gender preferences. Through in-depth research and article references, using previous research studies information was received and recorded. This also gave an idea as to how queries or situations are dealt with. Besides the organization and the personal lives of employees and executives revolve around the norms set by the society. The rules and regulations set in organizations are also somewhat influenced by the societal norms.

Key Words: Patriarchy, Masculinity, Modern Indian society, Organization.

Introduction:-A dominating male society, where men hold primary political roles, moral authority, social authority and control of property. Some of these societies are patrilineal, that means property and title are inherited by the male lineage. Idea of inherent natural difference between men and women is the basic ideology behind this belief of Patriarchy. Sociologist's belief patriarchy is a social product and not as an outcome of innate differences between the sexes hence they focus on the way that gender roles in a society affect power differentials between men and women. These ideologies arise from the idea of Masculinity. Generally believed to be socially constructed, some research believes that certain behaviors considered masculine are biologically influenced. The extent of the biologically or socially influenced is generally a topic of debate. Certain traits like leadership, decision making ability, strength, courage, independence were traditionally considered masculine. But such beliefs differ across culture.

Need for the study:-It is important that the inequality against men and women is dealt with in an effective manner. Though we have laws in our country to deal with such situations, the results do not show any progress. The study focuses on the discriminations that take place in the corporate world for reasons that may not be so subtle. The main debating factor here would be the measures taken by the higher authorities of the organizations to curb or decrease the number of cases of discrimination. Hence, the need of the study is to understand how the individuals and the organizations deal with such situations.

Scope of the study

- The scope of the study is restricted to only working executives in Mumbai
- The study does not include all age categories.
- The study focuses on youth aged from 16 to 55.
- The study has no gender boundaries and focuses on opinions of everyone irrespective of their gender.

Aims and objectives of the study

1. To learn the concept of patriarchy and masculinity.
2. To understand whether patriarchy affects the executive's personal and professional life.
3. To explore the effects of masculinity on organizational/work relationships.
4. To learn the laws that exists against the gender discriminations at workplace.
5. To explore whether organizations are taking any steps eliminate patriarchy or gender preferences.

RESEARCH METHODOLOGY

Problem identification

This study is about patriarchy and masculinity and all the concepts that surround this topic. Patriarchy as we know is a platform that gives men or the head of the family an upper hand in taking all the decisions of the family whereas masculinity is the trait that men are expected to possess in order to be considered normal.

The area under consideration is the effects these concepts have on the personal and professional lives of men and women.

- The concept of men suffering due to patriarchy and masculinity enforcement is yet a new subject for the society since the notion of men being unhappy with having power in hand is abnormal. Hence, finding cases where men have complained about following the societal norms are very few. Finding a solution to an issue that is yet not recognized can be a challenge.

Methodology adopted

This study is made taking into consideration that the issue is prevalent in the society and the basic recognition of patriarchy and toxic masculinity has been initiated. The research explains in brief the entire concept of patriarchy and masculinity and how it affects daily lives of executives and professionals in all aspects.

Data for this study is collected through in-depth online research and usage of previous research data available on the sites.

Sample Unit – 31 participants

Sampling place – Mumbai

The secondary source includes all the articles, books, online references that include the information regarding patriarchy and the trait of masculinity. It focuses on the briefing of these concepts and in depth details of patriarchy and its roots in all aspects of individual's personal life and professional life.

Data analysis and interpretations:-In this survey the numbers of responders are in total 31. The men sum up to 16, the women sum up to 15 and we have no responders that belong to transgender and any other sexual identity. The responders to this survey belong to different age categories. Majority of the responders are in between 16-25 which probably means they have either started working early or have less qualification. 6 of the responders belong to age category of 26-35 which gives us responders who have spent enough time in corporate world or any other organization. 3 responders are of age in between 36-45 which can probably mean that they are both working and have a settled family or are independently living by themselves. 1 responder belongs in 46-55 age category which gives us an idea that the responder must have spent more than 30% of life time in an organization working among others. The analysis of the education level of the respondents concludes that 3% responder is an under graduate who has started working right after their higher education. 29% responders have completed their graduation course and thereafter started working. 68% responders have completed their post-graduation and started working in corporate. It is understood from the analysis that not many know people know the basic definition of patriarchy and masculinity. The awareness of societal norms and its technical terms are low even in educated individuals. To understand the same, it will be important for them to go look out for sites, articles or books that might help them understand these terms. This study showcases that most of our responders do recognize the existence of patriarchy and masculinity in our Indian society. Though the study covers very little portion of the Indian population, the sample shows that a smaller portion has either never faced any such situations or is unaware of these terms and may take such a hierarchy as normal in all families and in the organization as well. The analysis of the basic understanding of patriarchy and masculinity gave following responses from the sample.

- Patriarchy is the family system where in the male is the head of the household. Masculinity is when patriarchy becomes toxic, when male power is considered and exhibited to be supreme and made to feel that other genders are useless and not worthy for any form of activity,
- Patriarchy where in man is dominating. Masculinity is the features which highlights man. The society views of being man.
- male being higher than women and how this mentality affects men and women in society and career
- Patriarchal society is still considered as a way of life in India. It is deep rooted in our culture where even today sons are preferred over daughters.
- Male holds the power and women are excluded
- Where men hold the control and take decisions for the women and kids of the house.
- That men are superior or in some or the other way decision making is in their hands and also they are found more eligible for certain tasks
- Patriarchal masculinities is a term that can be used to describe those ideas about and practices of masculinity that emphasize the superiority of masculinity over femininity
- Patriarchal masculinities is a term that can be used to describe those ideas about and

practices of masculinity that emphasize the superiority of masculinity over femininity and the authority of men over women. Ideas about and practices of patriarchal masculinities maintain gender inequalities.

- Patriarchy: A system or hierarchy male members are considered to be the head of the family
Masculinity: All the characteristics that define a male like being rigid or strong.

The definitions provided by the responders vary on different scales. Some responders define it as a daily way of life whereas few define it as a hierarchy that excludes women from the decision making power. The men are considered as the head of the family, hence, making them the highest authority who will then have the others follow them and their rules. Few of the respondents are not really aware of the concepts.

Patriarchy and masculinity play an important role in deciding the employee's behaviour at home and at workplace. From the study, we understand that majority of the responders have neutral opinion about the influence that patriarchy and masculinity may have on the behavior of the employees when at home and when at work. Apart from the ones who have neutral opinion, we have responders who agree to have being influenced by patriarchy or masculinity and that affects their behavior at work and at home irrespective of it being positive or negative. It can be understood that majority of the sample population has faced pressure in their social or professional life to do an activity regardless of their willingness to do it. The pressure was built for a simple and plain reason that is their gender. Hence, we understand that gender biasness does exist in the society and it is prevalent in organizations as well. From the responses that we have gathered through the survey, we can understand that the biasness was not only against women but also men. One of the responder has claimed to be treated unequally compared to his female colleagues. But we have responders who claim that their men colleagues were treated much better than them. Also women employees have very less options and opportunities to travel at faraway places due to safety reasons. Majority of the sample population has witnessed pressure in their personal lives to do something that they were not willing to do initially. Few of the responders have faced these situations very so often but also we have responders who have not faced any pressure of any nature due to their gender. We understand through the responses that responders have witnessed some sort of discrimination against their male employees in the organizations. While majority of the responders have never come across any situation that might have been against the men employees of the organization.

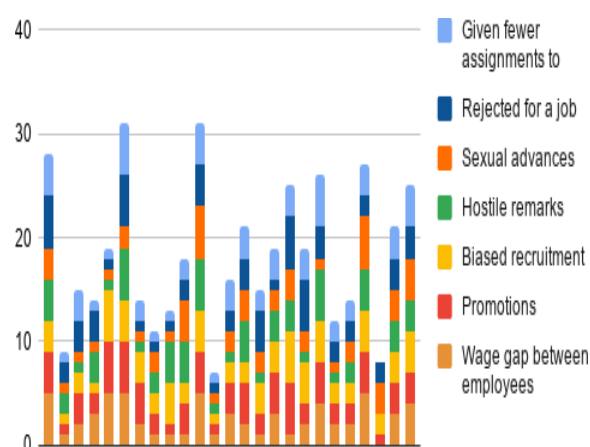

Figure 1: Types of discrimination seen (Source: Research data)

Through the graphical representation, we understand that the responders have rated all

the kind of discriminations with neutral ratings. It is safe to conclude that the discriminations against the employees (male) is very much prevalent and they are also targeted by the management or the colleagues for other advances in exchange of another profitable proposal for the employee. The responses clearly indicate that biasness exists and it has its influence on not just a few men but maybe on the entire men population. It could also be interpreted as favoritism in few cases. The study helps us understand that the responders have mostly given more preference to female dominant industries, competition between men and social position of men as the main reasons for the discriminations that happen against men. Female dominant industries prefer having women as their employees rather than having men as their employees. The competition in between men themselves could be considered as a reason for their morale to be affected. Social position of men can also be a major reason for them to be pressurized into doing some activity that they not willing to do. From the responses that we have collected, it's very evident that the relationship between male employees and female employees does get affected and continues for a long period of time. The inequality against either of the gender can cause a huge rift and eventually affect the productivity of the organization. Through the responses of the participants, we understand that most of them believe it's the male ego that is hurt when they face a situation where they are considered subordinate. Their masculinity is questioned. Their morale goes down and then they revert this negative energy in their domestic life. The expectations from both the genders have been ingrained in their minds since the very beginning and when that seems to be changing suddenly, they feel weak and out of control. Majority of the participants have never complained a file against discrimination that they themselves have faced or have witnessed happening around them. 2 of the participants have filed a case against whatever discrimination that they have come across. Most of the participants are not aware of any laws that could help them against any discrimination. Other half of the participants are not sure about the laws. Very few of the participants are aware of the laws and probably use them wisely. Most of the participants of the survey are aware of Article 14 that mentions equality before the law and equal protection of the laws. Majority of the participants in the survey recognize Article 15 that includes prohibition of discrimination against any citizen on the basis of religion, race, caste, sex, place of birth or any of them. More than 50% of the participants recognize the law that provides equal remuneration to all employees. For the rights of persons with disability act, 48.4% of the participants have agreed to know the law. From this survey, we understand that not all organizations have the tolerance towards indiscrimination against any employee whereas there are few organizations that realize and accept that discrimination takes place in their own companies and also work towards its eradication. We also understand that few companies do not even recognize any such concepts and maybe take this kind of behavior as natural. Through the responses we understand that not many organizations provide any different kind of cell that deals with such cases. Apart from a few companies that have their HR management handling such cases and women's cell who deal with harassment cases against women. Majority of the companies do not provide any such relief cells to file any case against any employee or executive. From the chart and responses of the participants, we can see that the laws implemented for the benefit of the employees are not really used when needed. The participants have given neutral ratings for the enforcement of laws. Hence, we can conclude that the organizations need to focus on the goodwill of their employees and work more on their social and professional growth. From the responses, we understand that the participants have the understanding of the situation and urge everyone to do their bit in decreasing the biasness among the

genders. It's also the responsibility of the management to look out for such a behavior and take action against such individuals. Treating all the individuals equally irrespective of their gender can help in bringing unity and equality with better growth.

Findings and conclusions

- a) The definitions provided on the concepts of patriarchy and masculinity on the sites online and the articles provided more or less match with the definitions that the responders have provided.
- b) The discriminations against all the individuals have not decreased but have taken new forms in corporate world.
- c) The biasness has not just targeted women but also men and they have been suffering through pressure since their childhood.
- d) The inequality is not just restricted in the corporate world but also in our homes and society.
- e) The effects on individuals vary by a large scale and their methods to deal with it also vary.
- f) Organizations are far away from building an equal environment for their employees since the recognition of gender inequality has not been accepted.

Recommendations from the study

This study is subjected to the following recommendations:

1. Recognition of discrimination against men

The discrimination against men has been going on since ages. The only difference is that it was not so evident in the earlier times. Even in this era, it is considered as natural for a man to be strong and not be emotional irrespective of the culture or religion they belong to. We as a society need to accept that men can also have their own right to make decisions by themselves and not follow the stringent rules of the society. Even in corporate, keeping unrealistic expectations from men just based on their gender need to be decreased. Freedom of will belongs to everyone and needs to be respected by everyone. Through the research, it is pretty much evident that corporate world does not really recognize the depth of the issue and has been ignoring it for their own profit. The laws are meant to protect everyone's dignity in the society and they need to be executed with just as much force. Taking employees mental and physical health is equally important as they have a huge impact on the profit of the organization. Employees play a huge role in the functioning of the organizations and hence keeping them safe and satisfied is the responsibility of the management of the organizations.

Learning outcome:- In the entire study of patriarchy and masculinity enforcement, we understood how these ideologies have been ingrained in our minds since our childhood and now since the times have changed, the need to judge individual choices need to be curbed. The effects on the mindset of the employees are quite deep and needs to be dealt with patience.

Strengths and limitations of the study

Strength: The strength of the study is that it provides us with basic information on the concepts of patriarchy and masculinity and has also given us perspectives of men and

what they think of the inequality against them.

Limitation: The secondary data collected for this study was inadequate since the perspective of men has not been studied deeply by researchers. The corporate inequality aspect was never quite studied hence, providing data on it is a major drawback.

Future scope of the study

- i. The study can be carried out in a detailed manner by increasing the time span of the study to over six months or one year.
- ii. This study is very narrow and restricted to executives only in Mumbai.

Bibliography

1. <https://www.vocabulary.com/dictionary/masculinity>- Meaning of masculinity2
2. <https://journals.sagepub.com/doi/abs/10.1177/09667350156279>, <http://www.learnwhr.org/wp-content/uploads/D-Facio-What-is-Patriarchy.pdf>
3. https://sg.inflibnet.ac.in/bitstream/10603/128477/8/05_chapter%201.pdf- Definition of patriarchy
4. <https://www.sciencedirect.com/science/article/pii/S1877042815050909>-Definition of masculinity
5. <https://nomas.org/understanding-patriarchy-and-mens-power/> ,
6. <https://hbr.org/2010/06/gender-and-the-future-of-the-o> ,
7. https://aorta.coop/portfolio_page/challenging-patriarchy-and-sexism/- Masculinity and patriarchy in corporate
8. <http://arno.uvt.nl/show.cgi?fid=81639>- Impact on employee relationships
9. <https://civilrights.findlaw.com/discrimination/gender-discrimination-applicable-laws.html>- Laws against gender discrimination-
10. <https://rm.coe.int/16806da342>- Implementation of gender discrimination laws

Performance appraisal process involves in retail industry

Research Scholar - Neha Upadhyay
Shri J.J.T.University

E-Mail- nehaczech@gmail.com

Introduction

1. Build up standards: initial phase in course of execution evaluation is foundation of standards or norms. Such standards or principles ought to be obviously characterized and quantifiable so that there is no disarray concerning what is to be accomplished. Such guidelines ought to be ordinary, achievable for representatives working under typical conditions or workplace. If there should arise an occurrence of piece of clothing fabricating unit such principles are obviously set down even by machine maker. Subsequently laborer working in piece of clothing unit can be given errand of creating some article of clothing say 100 article of clothing each day.

2. Communicate it to workers: following stage in course of execution examination is to illuminate or impart offered standards to representatives for their arrangement and input. They should know task they need to act in given time span say 8 hours of shift or 12 hours of shift. Their assent or affirmation is fundamental as they need to at last chronicle it.

3. Measuring real execution: following stage in course of execution evaluation is to embrace genuine estimation of work done. This is finished with assistance of various estimating instruments, for example, every day creation reports, individual perception, factual report and oral report.

Review of Literature

Kumar Deepak (2007) in his exploration paper dissected connection transport between Human Resources Management and execution the executives. Human Resource are generally intricate in nature as they vary as far as abilities, information, fitness, demeanor, conduct and these distinction bring about contrasts in hierarchical execution. Organist particles which utilize best HRM rehearses are consistently ahead in execution, usefulness proficiency and so on

Jahan K (2008) assessed working and working of some of public area associations in country and tracked down that these associations have embraced best human recourses arrangements and practices as far as enrollment and choice of representatives, preparing and advancement, worker strengthening ,pay structure and so on

Rabindranath Badi (2016) portrayed basics of sound and compelling execution evaluation framework. It incorporates shared trust between the board and workers. Shared trust is fundamental so representatives consider mgt. arrangements as sure endeavors to upgrade worker's efficiency.

Janeen Mai mona (2010) dissected effect of execution examination representative inspiration and found that it is significant apparatus of surveying proficiency of workers. It is helpful to the board just as representatives. Indra Devi (2012) concentrated on execution examination and authoritative execution. A discovery of examination uncovered solid relationship between's presentation evaluation and hierarchical execution.

Farooq Raees (2014) assessed various ways to deal with hierarchical execution. It incorporate adjusted score card, execution crystal, triple main concern and so on.

Satya watercourse and others (2012) looked at inspiration and work culture in open area and private area association. Discoveries of examination uncovered that representatives of public area are roused by their prosperity and accomplishments while workers in private area are inspired by work

Som Ashok (2008) assessed inventive HR rehearses and its effect on corporate execution.

Goyal and others (2012) directed exploration on HR rehearses and its effect on worker work fulfillment. Discoveries of examination uncovered that there is solid connection between's HR rehearses and workers inspiration and occupation fulfillment. In this manner associations ought to have complex HR plans for all workers. This arrangement ought to be founded on necessities of workers just as associations. Plan ought to be adaptable relying upon changing assumptions for workers.

Shubha Rao(2012) explored extent of human asset the board. extent of HRM incorporate destinations or objectives of HRM , association of HRM ,techniques of HRM , improvement of HRM ,compensation and pay, inspiration of representatives, keeping up with sound modern relations, participative administration and so forth elements of HRM can be delegated

Advances two designs move might have:

1. Level of improvement

It is an individual of the situation with the development that will be that by having the capacity of the sort of change of without. Senior speaker in for a mentor to enhance post to for any extra work tasks

2. Vertical Advancement

This work undertakings and commitments of the well - with an individual status and position of the structure that. Foreman's as in cutting edge a trained professional or overseer of AS in a foreman high significance of business that.

Objective

To study Retail industry performance appraisal

To study increase project team performance in retail industry

Methodology

Technique In this review, some chose markers are utilized to learn the exhibition of the retail business area. The first among them are incomplete and absolute factor usefulness (TFP) gauges, other than the capital-work proportion. Work efficiency, characterized as yield per work, is the fractional factor usefulness measure utilized in this specific situation. The capital-work proportion, estimated as genuine gross fixed resources isolated by complete number of people connected with, is the other factor proportion used to catch the patterns in the exhibition of the assembling area. As respects TFP development, we gauge the Cobb-Douglas (CD) creation work in condition. Poll based leave overview of purchasers' shopping at coordinated retail outlets and furthermore customers' shopping at sloppy outlets;

Result & Conclusion

The accompanying issues should be thought of while planning the presentation assessment framework:

1. Subjective and quantitative standards:

Workers can't be made a decision about absolutely on subjective or quantitative premise. Subjective evaluation includes individual inclination and abstract worth judgment. Quantitative evaluation dependent on factual information, then again, overlooks significant determinants of worker's adequacy

2. Examination among representatives:

Correlation among representatives can't be made on 'one man to another' premise as human component is associated with such examinations which varies in various circumstances. Various representatives work under various natural conditions and manage various items and clients in an unexpected way.

3. Deciding guidelines of execution:

The principles of execution ought to be logical and practical in light of the fact that the entire presentation assessment measure relies on guidelines. In case principles are ridiculous, the reason for execution assessment gets crushed.

4. Periodicity of assessment:

The time of assessment ought to be neither too long nor excessively short. Extremely transient assessment disregards the elements important for the firm over the long haul like growing great client relations.

5. Cycle of Performance Appraisal:

Execution examination measure comprises of the accompanying advances:

1. Objective setting:

Objectives are set for assessing execution which become principles. Principles ought to be pertinent, satisfactory and objective. There ought to be extension for extending human capacities. They ought to be high however sensible and feasible in a given circumstance.

2. Measure execution:

Whenever principles are set, next work is to quantify execution against norms. Estimation can be yearly, occasional or nonstop.

3. Discover deviations:

Directors notice genuine execution of workers, check out the natural conditions and discover deviations in execution.

4. Restorative activity:-A few deviations are attractive and some are unfortunate when looked at against objectives/norms. Remedial moves are made and sometimes, the objectives are adjusted.

Reference

1. Dr Ravindranath Badi (2016), Human Resource Management, Himalaya Publishing House, page: 235
2. Dr. Phillip (2013), Impact of HR Practices on Employee Performance, www.articles.eezzi.com
3. Kumar Deepak (2007) Garment Exports in India Pre & Post Liberalisation, SNDT Women's University.
4. Dr. S. Jansirani, Mr. R. Hatrikrishnan, Mrs. D. Jaya Kani, Ms. A. Saisathya (2013), study of performance appraisal system at Wipro Infrastructure Engineering Pvt Ltd, IOSR Journal of Business & Management (IOSR-JBM), 2278-478X, 2319-7668
5. Jahan K (2008) research study on employee appraisal system, case of Hong Kong & Shanghai Banking Corporation (HSBC Bank), International Journal of business & management invention, Vol
6. Dr. J. Vincent Xavier (2015), study on effectiveness of performance appraisal system & its influence with socio-demographic factors of employees of manufacturing industry in Tamil Nadu, International journal of research in management & business, Vol 2
- Ravindranath Badi (2016) analysis of marketing performance appraisal, problems of small & medium sized enterprises, International journal of innovative security, Vol 2 issue 3 22
7. Janeen Mai mona (2010) On the nature, consequences and remedies of workplace incivility: not time for nice? Think again', Academy of Management Executive, 19(1), pp. 7-18.

8. Petersen, J., Kaplan, E. and Samuels, A. (2007) Effects of Subordinate Likeability and Balanced Scorecard Format on Performance-Related Judgments', *Advances in Accounting*, 23, pp.85-111.
9. Indra Devi (2012) Motivation: How to increase project team performance', *Project Management Journal*, 38(4), pp. 60-69.
10. Rowland, A. and Hall, D. (2012) Organizational justice and performance: is appraisal fair?', *EuroMed Journal of Business*, 7(3), pp.280 – 293.
11. Farooq Raees (2014) Generating a scale measuring hierarchy of basic needs', *Procedia -Social and Behavioral Sciences*, 15(1), pp.3084-3094.
12. Satya wadi & others (2012) Performance management benefits organizations and their employees', *Human Resource Management International Digest*, 20(6), pp.3 – 5.
13. Som Ashok (2008) Improving performance appraisals using a real-time talent management system: The advantages of a real-time talent management system', *Human Resource Management International Digest*, 18(4), pp.35 – 37.
14. Goyal & others (2012) *Managing People and Organizations*. Amsterdam: Emerald Group Publishing.

REVISITING WOMEN THROUGH GOVERNMENT SUPPORTING SCHEMES

Mohd. Javed-Research Scholar
JJT University, Rajasthan
Email id: mohd_jawed07@yahoo.com

Abstract:-The status of women has been short sighted by the society of patriarchal for many decades but today women is rising to the occasion and believing in herself by breaking the barriers of cultural and social and creating new avenues to fit into new roles and integrating them to be part of developing herself, their family and nation. As said that the empowered woman is powerful beyond measure and beautiful beyond description. The essence is to enhance the productive roles and capacity of women. It was therefore argued that if women were given the opportunity to be actively involved in productive sphere, they will no doubt, contribute significantly to progress. Women make positive contribution and progress their position with consistency and determination. This paper conceptually discusses the importance of women empowerment and the impact of government schemes initiated in India and their success journey.

Keywords:- women, empowerment, determination, barriers, new role, integration, progress

Introduction:-The Government promotes India's entrepreneurial ecosystem by providing easy access to loans, networks, markets and training. The Government of India has introduced various schemes for women namely Prime Minister's Employment Generation Programme, and Support Training and Employment Programme for Women (STEP) who has had no access to formal skills, especially in rural India. Even though, the government has introduced numerous schemes for the promotion of women entrepreneurship and empowerment for sustainable development goals.

To call woman the weaker sex is a libel; it is man's injustice to woman. If by strength is meant moral power, then woman is immeasurably man's superior.

M. K. Gandhi

MAHATMA, Vol. 3, p. 33



Source: google.com

Five Government Schemes working for Women Empowerment

Beti Bachao Beti Padhao

Among the government schemes for the women, the very first scheme which comes to our mind is 'Beti Bachao Beti Padho'. This revolves around the notion of female feticides. It is campaign which aims at abolition of female feticides and to make girls socially and financially self-reliant through education. The movement came into force in 2015. It is a joint initiative run by the ministry of women and child development, the Ministry of Health and Family Welfare and the Ministry of human resource development. The movement also revolves around the actions to bridge the growing gap between the girl and boy infants.

Mahila-E-Haat

Mahila-E-Haat is a bilingual online marketing platform which helps aspiring women entrepreneurs, self-help group, and NGOs to showcase their products to the world. The platform is open to all Indian women above the age of 18. It is an initiative by the Ministry of

Women and Child Development and was launched in 2016. The platform is very user-friendly and provides an easy sign-in process with convenient payment modes.

Mahila Shakti Kendra

Another important initiative by the government is the Mahi Shakti Kendra. The scheme came into force in 2017 and it aims to empower rural women with opportunities for skill development, employment, digital literacy, health, and nutrition. In this scheme each of the Mahila Shakti Kendra provides an interface to the rural women so that they can approach the government to avail their entitlements through training and capacity building. It works at four levels, national, state, district and block levels.

One-Stop Centre Scheme

The One Stop Centre Scheme or popularly known as 'Sahki'. This scheme came into being in 2015 with the 'Nirbhaya' fund. The main aim of Sahki or One Stop Centre Scheme is to provide shelter, police desk, legal, medical and counseling services to the victims of violence. It has been established at locations throughout the country. It has an integrated with a 24-hour helpline. The toll free number to remember is 181.

STEP

STEP or Support to Training and Employment Programme for women. STEP aims at providing skills and competencies to women which will lead to employability. Under this scheme, a particular project is provided for duration of 5 years, depending upon the nature of it, kinds of activities involved and the number of beneficiaries to be undertaken. It provides help in sectors including agriculture, horticulture, handicraft, computer handlooms, tailoring, etc. With this, it also provide help and support in skills like spoken English, it and computer, travel and tourism, hospitality, etc.

Review of literature

1. **Uma SN and Ramesh HN (2018)** stated in their study have pointed out that emerging entrepreneurs are just like newborn babies. They cannot stand on their own feet. Hence, at least in the initial stages of their business necessary support may be extended by the Government for their survival and sustainability. Thus, both State and Central Government have to take necessary steps to reach the ultimate beneficiaries
2. **Shiralashetti, A. S. (2013)** suggested that the Government has to organize necessary programmes for educating and spreading awareness about new schemes among women entrepreneurs
3. **Garba (2012)** mentioned that Government or policy makers should conduct workshops and seminars among interested women entrepreneurs in order to create knowledge of new schemes offered by the government
4. **Ashappa, C and Sedamkar (2011)** in their study observed that rural women entrepreneurs are unaware of policies and schemes offered by Central and State governments. The government should
5. **Rizvi and Gupta (2009)** in their study have argued that government supported advancement activities help only urban and middleclass female members due to their information access and level of education take the initiative to create awareness of the schemes and subsidies among women.
6. **Singh and Beiwal (2008)** mentioned that the Government may formulate different strategies and plans for Wes, but there is a gap between intent and execution

Objectives of the study

1. To study different government schemes to empower women
2. To identify the impact of Support to Training and Employment Programme(STEP) (A government scheme) on women empowerment

Research Methodology

Research in common pursuance refers to a search for knowledge in a scientific and systematic way for pursuant information on a specified topic.

Type of Study: descriptive

Secondary data

In this study secondary data has been adopted for sourcing. It is the data already existing, which has gone through some standard analysis. Under the secondary data, journals and internet were taken into consideration.

Limitations of the study:

Only secondary data has been sourced for the study

Time constraint

Only one government scheme for women has been discussed for the study

About STEP:-Highlights of Support to Training and Employment Programme(STEP)
The assistance under STEP Scheme will be available in any sector for imparting skills related to employability and entrepreneurship, including but not limited to the Agriculture, Horticulture, Food Processing, Handlooms, Tailoring, Stitching, Embroidery, Zari etc, Handicrafts, Computer & IT enable services along with soft skills and skills for the work place such as spoken English, Gems & Jewellery, Travel & Tourism, Hospitality.

Scheme Target Group

The scheme is intended to benefit women who are in the age group of 16 years and above.

Eligible Organizations/ Project Implementing Agencies (PIA's)

Grants-in-aid under the STEP programme may be given to an institution having a distinct legal entity as under:

(a) Institutions or organizations set up as Autonomous Organization under a specific statute or as a Society registered under the Societies Registration Act, 1860 or Indian Trusts Act, 1882 (Not for profit) or other statutes.

(b) Voluntary Organizations or Non-Government Organizations registered under the Societies Registration Act, Indian Trust Act carrying out activities which promote the objectives of the STEP programme, with adequate financial and other resources, credibility and experience of the type of activities to be undertaken.

(c) Co-operative Societies.

Success story of empowered women through government scheme

Rekha Pandram, 34, is a Gond woman who has transformed the lives of more than 7,500 women and their families across 40 villages in the Dindori district of Madhya Pradesh, India. Born into a poor family in the village of Amdari, Pandram was forced to leave school after only eight years and work as an agricultural labourer to support her family. Like many village women, she had very little say in the decisions made by her family despite contributing to the household income.

Although she was married at 19 and expected to adopt the role of housewife, Pandram remained motivated to learn, grow and lead.

In 2008 she became a member of one of the self-help groups set up through the IFAD-supported **Tejaswini Rural Women Empowerment Programme**, in the village of Phulwahi.

The programme is designed to empower rural woman so that they can take advantage of economic and social opportunities. Self-help groups such as the one Pandram joined also give women a chance to be involved in decision-making processes – often for the first time – and allow them to gain control over their lives.

Pandram's determination to make a difference was recognized early on. With encouragement and technical training she advanced as a member of the village level committee and was selected to represent her self-help group and village at the federation level, eventually becoming the secretary of the Nari Chetana Mahila Sangh, a federation of women's self-help groups formed under the IFAD-supported Tejaswini programme. At the same time Pandram found time to study and passed her high-school exam and now she is planning to take her higher secondary certificate exam.

In line with the objectives of the IFAD-supported programme, Pandram's federation began work with 1,500 women in 40 villages teaching them to cultivate and market minor millets – Kodo and Kutki. In 2013, the women all agreed to sow minor millets on 0.5 acres of their land.

Minor millets are traditional crops that are being promoted by the programme. In India, as in other countries, wheat had been used to replace local crops, but the millets are hardier than wheat, coping better with water scarcity and rocky land.

The Federation later extended its work to include de-husking the millets, and this has become one of the most successful enterprises in the Dindori district to date. The women taking part in this initiative are now earning good incomes. But most importantly, they and their families are eating well because the millets are highly nutritious.

However, Pandram's work did not stop there. Many of the villagers living in the tribal-dominated Dindori district live in impoverished conditions with marginal land holdings and underutilized resources.

Her aim was not only to ensure economic well-being, but also to further improve the nutrition of participating households. By following her lead in sowing seven different green vegetables in plots of land behind their houses, more than 3,000 women were able to harvest fresh green-leafed vegetables from their plots to use for meals on a daily basis. As a result of her "seven-days-seven-vegetables" initiative, the nutritional status of the women and their families started to improve.

To share her experience and knowledge, Pandram attended the Commission on the Status of Women in New York in March 2017 and spoke at the IFAD side event "Empowering rural women to develop resilient, sustainable livelihoods and communities".

She recounted the federation's success with the minor millets. "Previously we were only getting 12 rupees per kilo of minor millets, 15 for other types of millet," she said.

"But now with the support of the Madhya Pradesh government and IFAD, we have established a processing unit in the village, and started processing minor millets and packaging them. We are now getting up to 80-90 rupees per kilo. We have given our name to this product and it has our brand."

Conclusion

- While breaching traditional barriers, women in today's India are raring to leave their mark in varied sectors and make an impact in diverse set-ups. This has been well-supported and facilitated by various government policies and initiatives. Innovations and government schemes like Pradhan Mantri MUDRA Yojana, Mahila Shakti Kendra, Mahila e-Haat and TREAD have resulted in an increasing number of women venturing into entrepreneurship and breaking financial and social barriers. There should not be any let-up in such efforts.
- The relationship between women's empowerment and economic development is bidirectional: while development itself could bring down inequality, achieving gender equality is a prerequisite to achieving the other Millennium Development Goals including eliminating poverty and achieving overall development.

- Eliminating gender barriers and empowering women to be financially independent will not only have a thoughtful behavior on the health, education and overall well-being of women. Financial incapacity and allied stress have been found to have a negative influence on the ability of a person to parent effectively.
- The key factor that makes women's entrepreneurship a crucial venture for a government is the result it creates with in addition to the tangible effect of the enterprises themselves. The success of these women entrepreneurs could inspire other women to contribute in the entrepreneurial space. In turn, could provide employment to other women in their neighbourhood, relations and to the nation. These small steps come together to add towards a superior aim of economic development — increasing access to livelihood, and drive economic growth.
- Significantly targeted campaigns similar to StreeShakti, UdyamStree campaign have a critical role in shaping the future narrative.

References:

1. **Uma, S.N and Ramesh, H.N (2018).** A Study on Government Support for Promoting Women Entrepreneurs in Karnataka State. *International Journal of Economics and Management Sciences*, 7(3), 521
2. **Shiralashetti, A.S (2013).** Awareness level towards Government Schemes-A study of Women Entrepreneurs of North Karnataka Districts (Part of UGC Supported Major Research Project). *Summer Internship Society*, 5, 24-33.
3. **Garba, A.S (2012).** Entrepreneurship, public policy and poverty reduction in Nigeria. *International Journal of Business and Social Research*, 2(2), 158-169.
4. **Ashappa, C and Sedamkar, H (2011).** Women empowerment and rural development: Policies and programmes in Gulbarga District. *Indian Streams Research Journal*, 1, 1-13.
5. **Rizvi, A. F and Gupta, K. L (2009).** Women entrepreneurship in India—problems and prospects. *OORJA Journal of Management and IT*, 7 (2), 35-41.
6. **Singh and Belwal (2008).** Entrepreneurship and SMEs in Ethiopia: Evolving Role, Prospects and problems faced by women in emergent sector Gender management. *An International Journal*, 23(2), 12-136 [3]

The impact of IFRS on financial statement disclosures by Indian Firms

Ajay Lunawat, (Scholar, Shri JJTUniversity)

Dr. Chitra M. Barbade, (Co Guide, Shri JJT University)

Dr. B.S. Gaikwad, (Guide, Shri JJT University)

ABSTRACT:-This paper compares the converged Indian Accounting Standards (Ind AS) with the International Financial Reporting Standards (IFRS). The study finds that there are several areas where the Indian Accounting Standards variate from the International Financial Reporting Standards. The major reason for such deviation is difference in the global and Indian business and legal environment. This study highlights the major areas of differences between the IFRS and Ind AS. The differences as being highlighted in the study will give an insight to the regulators, policy makers, auditors and users of financial statements for a better understanding and assessment of implication of Ind AS.

Keywords : Accounting Standards, Ind AS, IFRS, Accounting, Indian GAAP

INTRODUCTION:-The users of financial statement includes various stakeholders like investors, regulators, financers and researchers. Disclosures in the form of notes to accounts provide additional information to the financial statements for decision making. Financial Reporting Standards (IFRS Standards) issued by the IASB, which were being recognized as Global Financial Reporting Standards and they focus on more disclosures. In February 2015, Ind AS recommended by ICAI were notified by Ministry of Corporate Affairs (MCA) in consultation with National Advisory Committee on Accounting Standards (NACAS). Ind AS are substantially converged with IFRS Standards, which have got implemented by all the listed companies and also large part of unlisted companies in phased manner. As per the Ind AS, the firms need to provide higher level of disclosures when compared to the local GAAP. There are various standards in Ind AS which specifically provide for disclosures

LITERATURE REVIEW

Ghassan et al., (2012) looked at the segmental data revelations of Jordanian organizations under IFRS 8 for 2009 with exposures under IAS 14R for 2008. The found increase in the disclosures related with segmental information under IFRS when compared with IAS 14R.

Malaquias & Zambra, (2018) analyzed the disclosure level of the financial instruments given by the mining organizations situated in the Latin America. Internet access was rejected as a variable for the disclosure level and firm's listing status at NYSE, firm's profitability and country infrastructure where the firm is located were found to be not significant.

Yasean A. et al., (2016) examined the relationship between the market value of the firm and the Financial Instruments disclosures by the Jordanian listed companies. They concluded that Jordanian companies which highly complied with FI disclosure requirements had higher value relevance.

Iatridis, (2008) studied the motives and benefits of voluntary disclosures in the financial statements of UK firms. The firms which reported extensive disclosures were also benefitted with higher returns.

Tsalavoutas, (2011) examined 153 Greek listed companies level of compliance with the mandatory disclosure requirements as per the IFRS. The compliance was measured in relation to changes in the basic financial ratio and was found to be significantly observed. The applied two different disclosure index to measure the compliance level by the firms.

RESEARCH METHODOLOGY

The study is an empirical study and an explanatory study. The sample size is 75 BSE listed companies who have mandatorily adapted IFRS w.e.f 1st April 2016. The study period is from 2010 to 2019. The data type is secondary data. The source of data is derived from the annual reports of the companies and CMIE prowess database. The statistical tools used in the study are panel data regression. The variable of interest is the IFRS dummy which is a dummy variable. The dependent variable is notes pages and independent variables are firm size, firm leverage. The control variables are current ratio and return on assets. The empirical model used in the study is

$$NPAGES = \alpha + \beta_1 IFRS + \beta_2 SIZE + \beta_3 DEBT + \beta_4 CRATIO + \beta_5 ROA + \varepsilon$$

Where NPAGES is number of notes pages

IFRS is a year dummy

SIZE is log of total assets

DEBT is the leverage of the firm

CRATIO is current ratio

ROA is return of assets

DATA ANALYSIS

The descriptive statistics are provided below in Table 1 for pre Ind AS period and Table 2 for post Ind AS period

Table 1 Descriptive Statistics – Pre Ind AS

	Mean	SD	Skewness	Kurtosis
NPAGES	35.791	11.049	.401	3.518
SIZE	25.542	1.458	.142	2.54
DEBT	.08	.111	1.616	5.424
CRATIO	2.585	3.428	5.754	44.28
ROA	.116	.091	2.094	14.476

Table 2 Descriptive Statistics – Post Ind AS

NPAGES	60.249	17.659	1.237	4.854
SIZE	26.175	1.297	.369	2.577
DEBT	.073	.11	1.949	6.827
CRATIO	1.796	1.101	1.576	6.784
ROA	.107	.093	2.556	15.668

From the table 1, it is observed that the mean of notes pages (NPAGES) was 35.791 in the pre Ind AS period. The mean of firm size was 25.542 in the pre Ind AS period., debt ratio is .08 in the pre Ind AS period., current ratio is 2.585 in the pre Ind AS period. and return on assets is 11.6 % in the pre Ind AS period.

The table 2 shows that the the standard deviation of notes pages (NPAGES) was 60.249 in the post Ind AS period. The standard deviation of firm size was 26.175 in the post Ind AS period, debt ratio is .07 in the post Ind AS period, current ratio is 1.796 in the post Ind AS period and return on assets is 10.7 % in the post Ind AS period.

From the table 1, it is observed that the standard deviation of notes pages (NPAGES) was 11.049 in the pre Ind AS period. The standard deviation of firm size was 1.458 in the pre Ind AS period., debt ratio is 0.111 in the pre Ind AS period., current ratio is .3428 in the pre Ind AS period. and return on assets is 9.1 % in the pre Ind AS period.

The table 2 shows that the the standard deviation of notes pages (NPAGES) was 17.659 in the post Ind AS period. The standard deviation of firm size was 1.297 in the post Ind AS period, debt ratio is 0.11 in the post Ind AS period, current ratio is 1.101 in the post Ind AS period and return on assets is 9.3 % in the post Ind AS period.

It is observed that the mean of notes pages have increased in the post Ind AS period after the implementation of Ind AS.

Table 5: CORRELATION ANALYSIS

Variables	(1)	(2)	(3)	(4)	(5)	(6)
(1) NPAGES	1.000					
(2) IFRS	0.645*	1.000				
	(0.000)					
(3) SIZE	0.459*	0.202*	1.000			
	(0.000)	(0.000)				
(4) DEBT	0.192*	-0.030	0.306*	1.000		
	(0.000)	(0.420)	(0.000)			
(5) CRATIO	-0.163*	-0.123*	-0.052	-0.227*	1.000	
	(0.000)	(0.001)	(0.159)	(0.000)		
(6) ROA	-0.160*	-0.043	-0.278*	-0.432*	0.283*	1.000
	(0.000)	(0.241)	(0.000)	(0.000)	(0.000)	

*** $p < 0.01$, ** $p < 0.05$, * $p < 0.1$

From the Table 5 above, it is found that the correlation between IFRS and notes page is 0.645 and significant. The correlation between firm size and notes pages is 0.459 and significant. The correlation between firm size and Ind AS is 0.202 and significant. The correlation between firm leverage and notes page is 0.192 and significant. The correlation between firm leverage and Ind AS is -0.030 and not significant. The correlation between firm leverage and firm size is 0.306 and significant. The correlation between current ratio and notes page is -0.163 and significant. The correlation between current ratio and Ind AS is -0.123 and significant. The correlation between current ratio and firm size is -0.052 and not significant. The correlation between current ratio and firm leverage is -0.227 and significant. The correlation between return on asset and notes page is -0.160 and significant. The correlation between return on asset and Ind AS is -0.043 and not significant. The correlation between return on asset and firm size is -0.278 and significant. The correlation between return on asset and firm leverage is -0.432 and significant. The correlation between return on asset and current ratio is 0.283 and significant.

The results of the pooled OLS regression are provided in Table 4 below

Table 4: POOLED OLS REGRESSION RESULTS

NPAGES	Coef.	St.Err.	t-value	p-value	[95% Conf	Interval]	Sig
IFRS	21.998	.993	22.16	0	20.049	23.947	***
SIZE	3.86	.342	11.30	0	3.189	4.531	***
DEBT	15.188	4.692	3.24	.001	5.976	24.4	***
CRATIO	-.333	.161	-2.07	.039	-.648	-.017	**
ROA	2.397	5.524	0.43	.664	-8.448	13.242	
NPAGES	-63.552	8.78	-7.24	0	-80.788	-46.315	***

Mean dependent var	43.445	SD dependent var	17.604
R-squared	0.544	Number of obs	719
F-test	170.176	Prob > F	0.000
Akaike crit. (AIC)	5611.074	Bayesian crit. (BIC)	5638.541

*** $p < .01$, ** $p < .05$, * $p < .1$

The results from the pooled OLS regression provided in Table 3 above show the coefficient of IFRS dummy is 21.998 and is statistically significant. It shows that in the post Ind AS period, the notes pages have increased by 21.998 pages. This leads to acceptance of the hypothesis Ind AS has a positive impact on the disclosures by Indian firms. The coefficient of firm size (SIZE) is 3.86, the coefficient of firm leverage (DEBT) is 15.188, the coefficient of current ratio (CRATIO) is -0.333 and the coefficient of return on assets is 2.397. The firm size was found to positively and significantly impact the firms disclosures, the firm leverage was also found to significantly and positively impact the firms disclosure. The current ratio was found to negatively and significantly impact the firm disclosure and the return on assets was having a positive and not significant association with firm disclosures.

After running the pooled OLS, the Breusch and Pagan Lagrangian multiplier test for random effects was conducted and the results ($\chi^2=534.53$, $p < 0.1$) show that the data is panel data. After which the panel data regression with random effects was carried out. The results are provided in Table 5 below

Table 5: PANEL DATA RANDOM EFFECTS REGRESSION RESULTS

NPAGES	Coef.	St.Err.	t-value	p-value	[95% Conf	Interval]	Sig
IFRS	21.682	.841	25.78	0	20.034	23.331	***
SIZE	4.953	.611	8.10	0	3.755	6.151	***
DEBT	16.672	5.501	3.03	.002	5.89	27.454	***
CRATIO	-.113	.171	-0.66	.511	-.448	.223	
ROA	6.081	6.679	0.91	.363	-7.008	19.171	
Constant	-92.73	15.681	-5.91	0	-123.463	-61.996	***

Mean dependent var	43.445	SD dependent var	17.604
Overall r-squared	0.537	Number of obs	719
Chi-square	1205.381	Prob > chi2	0.000
R-squared within	0.648	R-squared between	0.327

*** $p < .01$, ** $p < .05$, * $p < .1$

The results from the panel data random effects regression provided in Table 5 above show the coefficient of IFRS dummy is 21.682 and is statistically significant. It shows that in the post Ind AS period, the notes pages have increased by 21.682 pages. This leads to acceptance of the hypothesis Ind AS has a positive impact on the disclosures by Indian firms. The coefficient of firm size (SIZE) is 4.953, the coefficient of firm leverage (DEBT) is 16.672, the coefficient of current ratio (CRATIO) is -0.113 and the coefficient of return on assets is 6.081. The firm size was found to positively and significantly impact the firms disclosures, the firm leverage was also found to significantly and positively impact the firms disclosure. The current ratio was found to negatively impact the firm disclosure but not significant and the return on assets was having a positive and not significant association with firm disclosures.

To check the robustness of the results, the panel data with fixed effects was operationalised and the results are discussed in Table

Table 6: PANEL DATA FIXED EFFECTS REGRESSION RESULTS

NPAGES	Coef.	St.Err.	t-value	p-value	[95% Conf	Interval]	Sig
IFRS	20.231	1.001	20.21	0	18.265	22.197	***
SIZE	7.505	1.069	7.02	0	5.405	9.604	***
DEBT	16.266	6.172	2.64	.009	4.145	28.386	***
CRATIO	-.059	.184	-0.32	.749	-.421	.303	
ROA	6.922	7.683	0.90	.368	-8.166	22.01	
Constant	-158.12	27.336	-5.78	0	-211.799	-104.441	***

Mean dependent var	43.445	SD dependent var	17.604
R-squared	0.651	Number of obs	719
F-test	238.339	Prob > F	0.000
Akaike crit. (AIC)	5136.675	Bayesian crit. (BIC)	5164.142

*** $p < .01$, ** $p < .05$, * $p < .1$

The results from the fixed effect panel data regression provided in Table 6 above show the coefficient of IFRS dummy is 20.231 and is statistically significant. It shows that in the post Ind AS period, the notes pages have increased by 20.231 pages. This leads to acceptance of the hypothesis Ind AS has a positive impact on the disclosures by Indian firms. The coefficient of firm size (SIZE) is 7.505, the coefficient of firm leverage (DEBT) is 16.266, the coefficient of current ratio (CRATIO) is -0.059 and the coefficient of return on assets is 6.922. The firm size was found to positively and significantly impact the firms disclosures, the firm leverage was also found to significantly and positively impact the firms disclosure. The current ratio was found to negatively impact the firm disclosure but not significant and the return on assets was having a positive and not significant association with firm disclosures.

Overall it is found that IFRS has lead to a positive and substantial increase in disclosures amongst Indian firms. The large sized firms and leveraged firms provide more disclosure.

CONCLUSIONS & RECOMMENDATIONS

The current study investigated the impact of Ind AS implementation on the disclosures by the Indian firms. A sample of 75 firms over the period 2010 to 2019 was observed with the period 2010 to 2016 as pre IFRS period and 2017 to 2019 as post IFRS period. The study was carried out using the panel data analysis with the set of independent and dependent variables. Pooled OLS, random effects and fixed effects regression were carried out for the regression and to check robustness. From the results of the empirical data, it was found that there has been an increase in the disclosure by the Indian firms after the IFRS implementation. The study concludes that the Indian corporates have adapted the Ind AS in true spirits. It is also recommended that increased disclosure shall provide more information to users of financial statements

REFERENCES

1. Ghassan, H. M., Louise, C., & David, M. P. (2012). The impact of IFRS 8 on disclosure practices of Jordanian listed companies. *Journal of Accounting in Emerging Economies*, 2(1), 67–90.
2. Iatridis, G. (2008). Accounting disclosure and firms' financial attributes: Evidence from the UK stock market. *International Review of Financial Analysis*, 17(2), 219–241. <https://doi.org/10.1016/j.irfa.2006.05.003>
3. Malaquias, R. F., & Zambra, P. (2018). Disclosure of financial instruments: Practices and challenges of Latin American firms from the mining industry. *Research in International Business and Finance*, 45, 158–167. <https://doi.org/10.1016/j.ribaf.2017.07.144>
4. Tsalavoutas, I. (2011). Transition to IFRS and compliance with mandatory disclosure requirements: What is the signal? *Advances in Accounting*, 27(2), 390–405. <https://doi.org/10.1016/j.adiac.2011.08.006>
5. Yasean A., T., Theresa, D., Suzanne, F., & Power, D. M. (2016). The Value Relevance of Financial Instruments Disclosure: Evidence from Jordan. *Asian Review of Accounting, Ifrs* 7, 445–473.

WEB AND TOOLS OF ONLINE DIGITAL MARKETING

ABHIJEET BALASAHEB THANGE AND DR MADHU GUPTA
RESEARCH SCHOLAR AND RESEARCH GUIDE, SHRI JYT UNIVERSITY

ABSTRACT- Internet promoting is the most pivotal issue in the cutting edge showcasing period yet there was no past research that could recognize the devices of web showcasing before this review and it was the first study on the field of internet promoting devices. This examination was clear in nature and it has endeavored to recognize the significant devices of web showcasing from the ideas of conventional advertising devices. Overall organization is known as Internet that can trade data among clients and internet is the subset of web that caters explicitly to Web locales.

KEY WORDS-Internet, marketing and tool market

INTRODUCTION-

Introduction to Web Marketing

Web based marketing is turning into hotly debated issue in each business area, and slowly assumes genuinely significant part in any organization's multi-channel marketing procedure. It utilizes Internet to convey limited time marketing messages to customers. It incorporates email marketing, internet searcher marketing, online media marketing, many sorts of show publicizing (counting web flag promoting), and versatile promoting. Like other publicizing media, internet promoting habitually includes both distributor, who incorporates ads into its web-based substance, and sponsor, who gives commercials to be shown on distributor's substance. Other potential members incorporate publicizing offices that help create and place promotion duplicate, promotion server who mechanically conveys promotion and tracks insights, and publicizing subsidiaries who accomplish autonomous limited time work for sponsor.

Tools of Online marketing:

Show promoting - Display publicizing passes on its promoting message outwardly utilizing message, logos, activity's, recordings, photos, or different designs. Show sponsors as often as possible objective clients with specific qualities to expand advertisements' impact.

Web standard promoting - Web pennants or flag advertisements normally are graphical advertisements shown inside site page. Standard promotions can utilize rich media to consolidate video, sound, liveliness, buttons, structures, or other intelligent components utilizing Java applets, HTML5, Adobe Flash, and different projects.

Edge advertisement - Frame promotions were principal type of web standards. Everyday utilization of "flag advertisements" regularly alludes to conventional edge promotions. Site distributors join outline promotions by saving specific space on page.

Pop-ups/pop-uppers - spring up promotion is shown in another internet browser window that opens over site guest's underlying program window. Fly under advertisement opens another program window under site guest's underlying program window.

Gliding promotion - coasting advertisement, or overlay advertisement, is kind of rich media ad that seems superimposed over mentioned site's substance. Gliding advertisements might vanish or turn out to be less prominent after preset time-frame.

Growing promotion - extending advertisement is rich media outline promotion that changes measurements upon predefined condition, for example, preset measure of time guest spends on website page, client's snap on promotion, or client's mouse development over advertisement. Growing promotions permit sponsors to squeeze more data into limited advertisement space.

Interstitial promotion - interstitial advertisement shows before client can get to mentioned content, here and there while client trusts that substance will stack. Interstitial advertisements are type of interference marketing.

Text advertisements - text promotion shows text-based hyperlinks. Text-based promotions might show independently from page's essential substance, or they can be installed by hyperlinking individual words or expressions to promoter's sites. Message promotions may likewise be conveyed through email marketing or instant message marketing.

Web search tool Marketing (SEM) - Search Engine Marketing, or SEM, is intended to build site's deceivability in web crawler results pages (SERPs). Web search tools give supported outcomes and natural (non-supported) results dependent on web searcher's question. Web search tools regularly utilize viewable prompts to separate supported outcomes from natural outcomes. Web search tool marketing incorporates each of sponsor's activities to make site's posting more conspicuous for effective catchphrases.

Site improvement (SEO) - Search Engine Optimization, or SEO, endeavors to further develop site's natural hunt rankings in SERPs by expanding site content's pertinence to look through terms. Web search tools consistently update their calculations to punish low quality locales that attempt to game their rankings, making enhancement moving objective for sponsors. Numerous merchants offer SEO administrations.

Supported pursuit - Sponsored search (additionally called supported connections or search promotions) permits publicists to be remembered for supported consequences of quest for

chosen watchwords. Search promotions are frequently sold through continuous closeouts, where sponsors bid on catchphrases.

Online media marketing - Social media marketing is business advancement led through web-based media sites. Many organizations advance their items by posting incessant updates and giving uncommon proposals through their web-based media profiles.

Portable Advertising - Mobile publicizing is advertisement duplicate conveyed through remote cell phones, for example, cell phones, highlight telephones, or tablet PCs. Portable promoting may appear as static or rich media show advertisements, SMS (Short Message Service) or MMS (Multimedia Messaging Service) advertisements, versatile hunt advertisements, publicizing inside portable sites, or promotions inside versatile applications or games (like interstitial promotions, "advergaming," or application sponsorship).

Email Advertising - Email promoting is advertisement duplicate including whole email or piece of email message. Email marketing might be spontaneous, in which case sender might give beneficiary choice to quit future messages, or it could be sent with beneficiary's earlier assent (pick in).

Conclusion

Web based showcasing is developing step by step and internet promoting apparatuses are significant components of web based advertising. Showcasing is the imperative piece of any organization following not many years movements of every kind of advertising will be directed with web so we can verbalize promoting term as on the web or web showcasing or e-advertising. web based showcasing apparatuses permit to interface clients whenever from anyplace. Web promoting instruments are more adaptable and accommodation than conventional showcasing apparatuses. online item has two sorts advanced and actual item and item picture is considered as a unique item. web based evaluating technique is more affectability than customary showcasing cost since client can without much of a stretch look at cost on web.

References

- 1.American Marketing Association (2013, July) Definition of marketing. <https://www.ama.org/AboutAMA/Pages/Definition-of-Marketing.aspx>. Accessed 31 July 2015
- 2.Buss, A. & Strauss, N. (2009). The online communities handbook: building your business and brand on the web. USA: New Riders.
- 3.Kotler P (1986) The Prosumer Movement: a new change for marketers. NA-Advances in consumer research, 13:510–513
- 4.Lauterborn B (1990) New marketing litany: four Ps passé; C-Words take over. Advert Age 61 (41):26
- 5.McCarthy EJ (1964) Basic marketing, a managerial approach. Illinois: R.D. Irwin

A Study on the effect of Covid-19 prompting diminished active work and influencing the emotional well-being of people

Research Scholar: Ms. Aarti Amar Ahuja

Reg. No.: 20119030

Subject: Management

Email id- ahujaarti46@gmail.com

Mobile No. 9819242975

Dr. Harish Purohit

Research Guide

Shri J.J.T. University, Jhunjhunu

Abstract:-It's been more than a year that the pandemic situation has arrived. Prior when the situation arrived it didn't affect much since we thought that the lockdown might soon open and everything will be back to normal. But yet the situation is the same infect it's the worse. Everything is happening just sitting at home like studies, work, shopping etc. There is no physical activity or exposure and also it's affecting the mental health of individuals that is leading to the development of other problems. The study was conducted using random sampling method among 100 respondents comprising of individuals aged 15 to 55 years. The area covered is from Bandra to Borivali (Mumbai Suburban). The collected data is tested by using percentage method.

Keywords:- Pandemic, Lockdown, Physical Activity, Mental Health

Introduction:-The pandemic is a remarkable time all over the world. Around the world, broad social removing arrangements are established, limiting individuals' every day exercises and overall requests from governments requesting that individuals stay safe and stay at home. This obviously implies that a great many people will invest a lot of their energy (if not all) at home. These social removing measures imply that individuals have far less freedoms to be genuinely dynamic, particularly if exercises like strolling or cycling as transportation, or partaking in a relaxed movement eg: walks, going to meet friends etc are being confined. Besides, these extreme measures additionally make it such a great deal simpler to be inactive at home for significant stretches of time. The effect of this actual dormancy may almost certainly be seen in numerous spaces, for example, wellbeing and social consideration and the psychological prosperity of individuals all over the globe. When there are so many restrictions because of this and the individuals lead to be at home this leads to anxiety and also unbalanced emotions which cannot be controlled at times. This leads in affecting the mental health of individuals. This affect can take place on working or non working individuals anyone. If working then there is no work life balance because of the situation and non working has to be at home dealing with the same situation. Due to this there could be even unknown thoughts that tend to arise in the minds of individuals which leads to the development of other different types of diseases which take the lead in the lives.

Literature Review

Moghe Kshipra et al. (2020), learnt that the current circumstance of COVID-19 has influenced the understudies' emotional well-being, explicitly in certain perspectives. The expanding reasonableness and freedom among the adolescent in a manner questions the associated idea of the general public. Be that as it may, the job and significance of loved ones can't be subverted and stays an essential factor in dealing with emergencies. **Changwon et al.(2020)**, stated that because of the dependable pandemic circumstance and burdensome measures like lockdown and stay-at-home requests, the COVID-19 pandemic welcomes

adverse consequences on advanced education. The discoveries of our investigation feature the critical need to foster mediations and preventive methodologies to address the emotional wellness of understudies.

Objectives

1. To study the impact of Pandemic on the individuals
2. To study the impact of pandemic on mental health of individuals
3. To study the impact of pandemic in the reduction of physical activity of individuals

Hypothesis

1. **H1:** Pandemic has affected the mental health of individuals
H0: Pandemic has not affected the mental health of individuals
2. **H1:** Pandemic has led to the reduction of physical activity of individuals
H0: Pandemic has not led to the reduction of physical activity of individuals

Scope of the Study

This study helps to know about the challenges faced by the individuals. This also helps us understand that the phases that the individuals are going through physically, emotionally and mentally.

Limitations

1. The area of study is limited to Bandra to Borivali (Mumbai Suburban Region) only; hence the results may not be accurate for other areas
2. The age is limited to 15 to 55 years
3. Validity & Reliability of the data obtained depends on the responses from the Teacher. The time factor of the researcher is limited
4. The size of the sample comparing to the population is very less and hence it will not represent the whole population

Research Methodology

This study is conducted on the basis of Primary and Secondary research data collected

- **Primary source** is used to collect data through structured questionnaires, personal observations and pondering, interviews and surveys
- **Secondary data** like research papers, newspapers, journals, online reviews, online apps, magazines, testimonials were referred

Analysis and Interpretation

The survey data was collected by the use of structured questionnaire from 100 respondents of

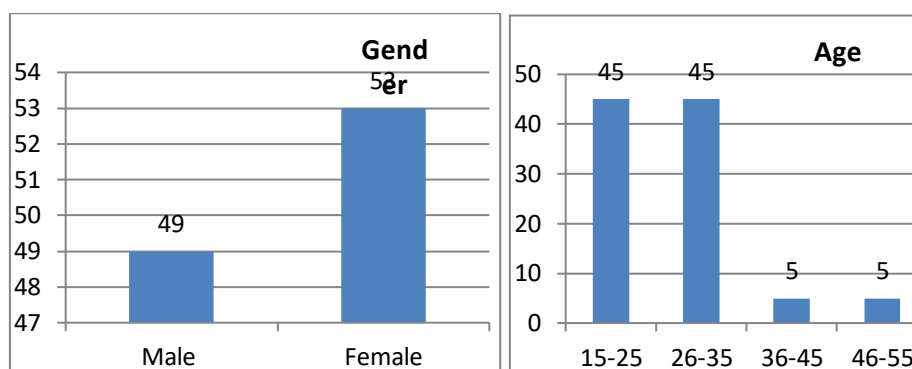

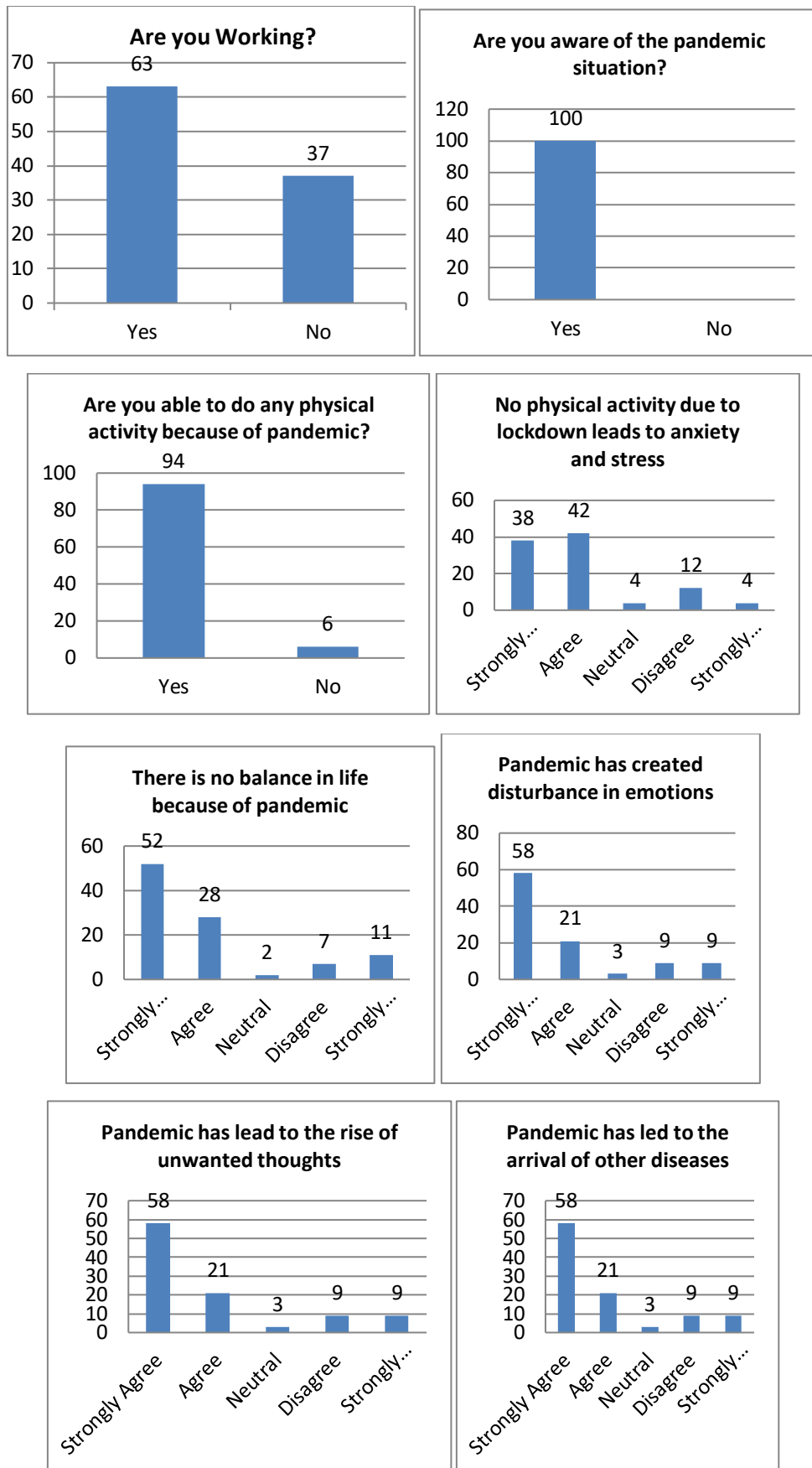

From the above graphs the researcher can say that Pandemic has changed everything and led to the destruction in the physical activity and affected the mental health of the individuals.

Suggestions

1. Training should be given to working individuals by their work places in order to handle stress
2. Yoga should be practiced by individuals
3. Individuals should not over think and should accept the situation as new normal
4. Positive thoughts should be considered
5. Online courses should be joined in order to be busy

Conclusion:-From the above study, it was known that pandemic has led to the arrival of new route in our lives which has to be followed by everyone though we all like it or not. With this current crisis taken place we have become dependent on the situation. If individuals cannot go out physical activities should be adopted at home and should not be stressed. This shall help in the reduction of anxiety and also won't affect the mental health.

References

Research Papers

- Moghe Kshipra et al. (2020). COVID-19 and Mental Health: A Study of its Impact on Students. DOI:10.1101/2020.08.05.20160499
- Changwon et al.(2020). Effects of COVID-19 on College Students' Mental Health in the United States: Interview Survey Study. JMIR, Vol. 22, Issue 9

Websites

- <https://www.thehindubusinessline.com/news/science/reduced-physical-activity-amid-covid-impacts-mental-health-study/article33818997.ece>
- https://www.physio-pedia.com/Physical_Activity_and_COVID-19
- <https://journals.plos.org/plosone/article?id=10.1371/journal.pone.0239696>

WORK LIFE BALANCE FOR GREATER EFFICIENCY & EFFECTIVENESS

ARUN K DATAR

ABSTRACT:-Balance between work and life, has as of late taken the consideration of the two specialists what's more, chiefs. This subject interests nearly everybody with a proficient vocation. This broad interest is incompletely because of its reflection on all parts of life. For the people who feel that the fundamental objective in life is to work, their profession turns into the centre of life. Be that as it may, individuals have restricted time and hence need to perform numerous different exercises other than their positions. In this review work – life balance is broken down from hierarchical setting. This review has the potential to empower the functioning individuals to consider their outlook in terms of work – life balance and family responsibility.

Key words: - work life balance, job satisfaction, work stress, family support.

INTRODUCTION:-Work-life balance is defined here as an individual's ability to meet their work and family commitments, as well as other non-work responsibilities and activities. Work life balance, in addition to the relations between work and family functions, also involves other roles in other areas of life. In this study, due to its more extensive associations, the concept of work–life balance is preferred. Work-life balance has been defined differently by different scholars. In order to broaden our perspectives, some definitions will be presented. Green haus (2002) defined work –life balance as satisfaction and good functioning at work and at home with a minimum of role conflict. Felstead et al. (2002) defines work-life balance as the relationship between the institutional and cultural times and spaces of work and non-work in societies where income is predominantly generated and distributed through labour markets. Ayca et al. (2007) confined the subject only with work and family and put forward the concept of “life balance” with a more whole perspective. Scholars defined life balance as fulfilling the demands satisfactorily in the three basic areas of life; namely, work, life and family.

Work demands work hours, work intensity and proportion of working hours spent in work. Additional work hours subtract from home time, while high work intensity or work pressure may result in fatigue, anxiety or other adverse Physiological consequences that affect the quality of home and family life. Father, mother, and so forth family obligations (e.g. childcare, house errands, and so on) caring for the old individuals, kids. Other than this, there are some different requests in work life balance than family and work live unwinding, get-away, sports and self-awareness programs. Work – life balance isn't the allotment of time, similarly among work, family and individual requests. In writing, it is too underlined that balance between fun and serious activities is emotional wonder that changes from one individual to another.

In such manner, balance between serious and fun activities ought to be viewed as distributing the accessible assets like time, thought and work admirably among the components of life. While some embrace the way of thinking of 'working to live' and considers work to be the target, others consider "living to work" and arranged work into the focal point of life.

DETERMINANTS OF WORK-LIFE BALANCE

Many things in life are the determinants of work life balance. The subjects in the literature that are related the most with work life balance are grouped here.

INDIVIDUAL:-An individual is the most important determinant of work –life balance. Two American cardiologists Rosenman and Friedman determined two different types of personality depending on heart disorders and individual behaviours: type A and type B. Type A expresses someone who is more active, more work oriented, more passionate and competitive, while Type B is calm, patient, balanced and right minded. It can be argued that since type A is more work oriented, there will be a negative reflection of it to work –life balance. Yet work holism, which is considered as an obsessive behaviour that destroys work-life balance. While work holism is like addiction to work, being at work for a very long time, overworking and busy with work at times out of work. Since life is not only about work, workaholics suffer from alienation, family problems and some health problems. Porter (1996) states that workaholics neglect their families, friends, relations and other social responsibilities.

FAMILY:-The requests that one’s involvement with day to day life and that can have impacts on life equilibrium can be given as the request of responsibility and time, job assumptions in family and backing to be given to the life partner. It is additionally remembered for the writing that such fluctuations as marriage, youngster rising, minding of the old at home, have impact on balance between serious and fun activities since they request all the more family obligations. The individuals who need to care for a kid or the older may in some cases need to hazard their vocation by shortening their functioning hours, which turns into a wellspring of stress for them. Then again, those without kids or any old to take care of at home experience less work-life unevenness.

WORK AND Organization:-Workplace is more successful in work-life unevenness than the family climate. The work furthermore, the establishment, one works in the two requests on his time, endeavors and intellectual ability. Among the endeavors to increment authoritative effectiveness, one of the subjects administrators center around is to raise the authoritative productivity, one of the subjects administrators center around is to raise the hierarchical devotion of the staff.

SOCIAL ENVIRONMENT:-Another determinant of work-life balance is social environment. Especially in countries that stand out with their culturally collectiveness. An individual also has responsibilities towards certain social groups he belongs to.

CONSEQUENCES OF WORK-LIFE IMBALANCE

The stress – based conflict occurs when one of the roles of the individual at work or in the family causes stress on the individual and this stress affects the other roles of the individual. The behaviour stress occurs when the behaviour at work and out of work are different and conflicting. 187 International Journal of Current Research, Vol. 3, Issue, 4, pp.186-189, April, 2011

PERSONAL IMPLICATIONS:-According to Lowe (2005), work life imbalance affects the overall well-being of the individual causing such problems as dissatisfaction from life, prolonged sadness, using drugs or alcohol.

INDIVISUAL IMPLICATIONS:-As indicated by Lowe (2005), work life awkwardness influences the general prosperity of the person causing such issues as disappointment from life, delayed misery, utilizing medications or liquor.

FAMILY IMPLICATIONS:-Association anticipates from individual to dispense more opportunity for their work while simultaneously the family needs him to play out his

obligations as well. The people who can't support balance between serious and fun activities are bound to encounter numerous issues in their families, for example, lower family fulfillment, diminished association in family jobs and so forth.

Hierarchical IMPLICATIONS:-Those whose requests of the family and one's social interest are not met properly normally like forfeiting his functioning hours, and complete their individual necessities.

Hierarchical PERSPECTIVE:-To diminish the adverse results of work-family struggle on working people, family agreeable authoritative culture and human assets applications have as of late been in plan of chief. The parts of the hierarchical technique are adaptable working hours , youngster care and older consideration plot, home working, work sharing. Strong projects for the family life of workers in an association add to giving work – life balance. Because of these programs, the workers will be supported, their participation will be upheld and their effectiveness will increment. Adaptable working hours is one of the strategies used to keep up with work-life balance. For instance representatives with flexi-time should satisfy specific measure of time week after week. Other thing which should be possible is to permit representatives to work at home away from conventional workplace.

End

In the event that one has figured out how to dispense the necessary time for each part of life appropriately and not to mix the issues in a single piece of life to another it implies that he has had the option to accomplish work-family adjust. Life in general is made out of numerous different viewpoints alongside work. The individuals who have accomplished a balance among these viewpoints make certain to accomplish the life balance, which gets rid of any irregularity.

References:

- 1]Chin, W. (1998). The Partial Least Squares Approach to Structural Equation Modeling. (G. A. Marcoulides, Ed.) LAWRENCE ERLBAUM ASSOCIATES, 295-336.
- 2]. Cohen, J. (1988). Statistical power analysis for the behavioral sciences (2nd ed.). Hillsdale: NJ:Lawrence Erlbaum Associates.
- 3]. Devellis, R. (1991). Scale Development : Theory & applications, Applied Social Research methods Series 26.Sage-Newbury Park.
- 4]. Devon, H., Block, M., Moyle-wright, P., Ernst, D., Hayden, S., Lazzara, D., & Kostas-Polston, E. (2007). A psychometric toolbox for testing validity and reliability. Journal of Nursing Scholarship,39(2), 155-164.
- 5]. Fatima, N., &Sahibzada, D. (2012). An Empirical Analysis of Factors Affecting Work-Life Balance among University Teachers: Tha case of Pakistan. Journal of International Academic Research, 12(1),34-48.
- 6]. Fornell, C., & Larcker, D. (1981). Structural Equation modeling and regression : guidelines for research practices. Journal of Marketing Research, 39(50), 39-50.
- 7]. Gayathiri, M., &Ramakarishnan, D. (2013). Quality of Work-Life kLinjage with Job Satisfaction and Performance. International Journal of Business and Management Invention, 2(1), 01-08.

A RESEARCH ON THE CHALLENGES OF WOMEN EMPOWERMENT THROUGH MICROFINANCIAL PERFORMANCE WITH RESPECT TO WOMEN SELF-HELP GROUPS IN THE NCR

SCHOLAR NAME - RAM NARAYAN SAINI

SUBJECT- COMMERCE

REGISTRATION NO. - 231218029

ABSTRACT:-Women's empowerment refers to expanding & improving women's economic, social, political, & legal authority. Women who are empowered get ability to enhance their economic situation & social well-being. Women are most essential members of our society, & they may play critical role in country's growth. Most essential component in women's empowerment, prosperity, progress, & welfare is education. Women who are educated may make significant contributions to growth of their families and, as result, society. Educated women have fewer & healthier kids, & they are more likely to raise their children to be educated & productive citizens like themselves, resulting in more stable & healthy society. Narrowing of economic opportunity gap between men & women in society is connected to increased economic development speed. Microfinance bridges gap by providing financial services to women all around world. Economic empowerment of women helps to gender equality, which has been linked to per capita GDP, human development indices, & competitiveness levels. Gender equality is also important for sustainable development, according to United Nations Sustainable Development Goals (SDGs). As result, MFIs & SHGs all around world focus their microfinance efforts on women.

KEY WORDS- Challenges, Empowerment, Microfinance, Self Help Group.

INTRODUCTION:-In India, self-help groups (SHGs) provide novel approach to financial inclusion. It blends low-cost, financially feasible services with self-management strategy to assist women self-help group members improve. NGO's (Non-Governmental Organizations), banks, & NBFC's are all involved in formation of self-help groups (non banking financial companies). Women's participation in Self Help Groups (SHGs) has good influence on member empowerment, both financially & in terms of community development. SHGs are often made up of ten or more members who are chosen from similar economic background & self-selected based on mutual trust & affinity. These members gather on regular basis, according to specified schedule, to collect their savings & pool them into common fund, which members then utilize to get loans. Organization creates its own set of laws, regulations, & penalties for breaking them (delay in repayment of loan, delay in savings). [1] Objective of SHGs is to break down barriers of merely saving & credit – & embrace notion of members' advancement in community, politics, intellectual circles, & financial life; hence, SHGs may be described as "mutual-growth institutions" or credit plus institutions. Microfinance programmes provide women opportunity to defy outmoded cultural conventions & improve their financial well-being. Microfinance program's main distinguishing feature is that it focuses on women's financial growth & empowerment. [2] In microfinance programmes, majority of members are women. Main premise of microfinance project is to empower women by giving autonomous financial support, allowing them to contribute to their families' income through self-employment. Self-belief, self-respect, self-worth, & other types of empowerment are generated as result of economic independence gained via microfinance projects. Process of SHG members' growth & empowerment is not automatic; it is dependent on number of elements, including ability, environment, initiative, & standing of women in society. Participation of women in SHGs has resulted in significant change in living patterns of financially disadvantaged impoverished women, as well as empowerment at many levels.

SHGs have empowered women not just on individual level, but also as members of home & in society. In subject of microfinance projects, there is growing corpus of literature. Several studies on concept of microfinance, its strategy, & function of microfinance projects have been done. However, there are few empirical research dedicated to identifying characteristics that contribute to women's empowerment through microfinance programmes. In this context, current study seeks to identify elements that lead to women's empowerment through self-help groups. [3]

DEFINITION:- Women's empowerment includes women's education & knowledge to improve their understanding of their surroundings, their ability to control their lives, their freedom from dominance by not relying on others' income, their ability to participate in decision-making, their ability to make independent decisions, & finally their mobility independence. [4]

The Self-Help Group (SHG) concept was established as fundamental approach for women's empowerment in Government of India's Ninth Five Year Plan (1997–2002) for this goal, & it is one of world's largest & fastest-growing microfinance programmes. Some argue that microfinance's economic impact empowers woman by increasing her income, which increases her negotiating power to manage household resources. Others argue that microfinance's social influence on increased autonomy, understanding, & political & social inclusion is more successful in empowering women. [5]

REVIEW OF LITERATURE

When compared to non-poor micro credit clients, study by Dr. Elizabeth Joey Henrique's & Dr. Rekha Rajesh Gaonkar (2011) shows that impoverished people use micro loans for productive & income-generating activities. Use of microcredit is also influenced by SHGs' age. It has been shown that SHGs that have been in existence for longer length of time are more likely to use loans to finance non-income producing activities. Members of SHG are also reliant on other financial institutions for their credit needs, according to data.

Dr. Elizabeth Joey Henrique's & Dr. Rekha Rajesh Gaonkar (2011) found that impoverished individuals employ micro loans for productive & income-generating activities when compared to non-poor micro credit consumers. Age of SHGs has impact on their utilisation of microcredit. SHGs that have been in operation for longer period of time have been demonstrated to be more prone to use loans to support non-income producing activities. According to statistics, members of SHG are also relying on other financial institutions for their credit requirements. [6]

Microfinance, according to Agarwal & Sinha (2010), is "the provision of financial services to low-income poor & extremely poor self-employed persons." These financial services often involve savings & credit, but they also include insurance & payment, among other things. 2011 (Bi & Pandey). Microfinance, according to Kaur (2014), is financial instrument that includes borrowings, savings, loans, insurance, & other fundamental financial services. Microfinance allows supply of small loans or funds (micro credit) to individuals who do not have access to traditional financial services, allowing them to start new productive economic activity or grow current ones.

According to Kundu (2016), microfinance programmes such as self-help bank linking programme are supported in India because of their beneficial economic impact. SHG participants have substantial & higher empowerment, according to data, & SHG microfinance programmes favourably contribute to financial transformation in households & empower women. Kaur's (2014) study, "Micro Financing via SHGs Empowering Women: In Indian Context," identified significant reasons for women to join SHGs. Women gain social & financial empowerment as result of their involvement in SHGs, which leads to self-employment through participation in economically productive activities.

Tehra (2014) said that microfinance operations including SHGs have been effective in achieving their aims of self-employment, women empowerment, income-generating activities, & poverty reduction. According to findings, SHGs are highly useful for socioeconomic development of BPL & low-income households. It was also discovered that several organizations have formed group businesses & personal employment with aid of microfinance. [7]

Poornima (2013) studied & demonstrated that SHGs are best formal micro-finance institutions for generating additional employment & income for needy people by involving them in planning, decision-making, & management of sustainable natural resources in some selected villages of Tumkur District of Karnataka. According to findings, many members, both individually & collectively, are engaged in entrepreneurial activities. It was also discovered that SHGs have lot of opportunity to start their own business. [8]

METHODOLOGY

A) Research Methodology

Because focus of this study is on different elements that contribute to women's empowerment among SHG members, exploratory research methodology was utilized. Systematic questionnaire was used to collect data. Questionnaire was distributed to women SHG members in order to perform pilot research. Their responses offered additional suggestions, which were then included into questionnaire to create more polished version. Goal of study was to figure out what elements contribute to women's empowerment in self-help groups.

B) Framework Example

For goal of collecting data for study, survey instrument in form of closed-ended questionnaire & structured personal interview were designed. Respondents were chosen using convenience sampling approach. Questionnaires were determined to be appropriate for analysis. Research was carried out in India's Delhi NCR. Study's unit of analysis was women from self-help organizations affiliated with several microfinance banks. Researchers utilized factor analysis to determine elements that contribute to women's financial & social empowerment through microfinance programmes. [9]

DATA ANALYSIS

Table 1: main reason for joining SHG

Prime Motive	Frequency
To develop saving habits	85
To get access to credit facilities	78
For achieving economic self reliance	16
For Socio political empowerment & sustenance	18
Others	0

According to table 1, 85 respondents joined SHGs to establish saving habit, 78 to gain access to credit, 16 to attain economic self-reliance, & 18 to gain socio-political empowerment & sustenance.

Table 2 shows duration of SHG's operation.

Category	Frequency
Less than one year	16
One year to three year	39
More than three year	45

Table 2 shows that 16 out of 100 respondents indicate their SHG has been operational for less than year, 39 say their SHG has been operational for 1 to 3 years & 45 say their SHG has been operational for more than 3 years.

Table 3: Group Meeting Frequency

Category	Frequency
Weekly once	10
Fortnightly once	45
Monthly once	45

According to table 3, 10 out of 100 respondents meet once week, 45 out of 100 meet every 15 days, & other 45 meet once month.

Table 4 shows amount of money saved each meeting.

Saving Amount Per Meeting	Frequency
Less than Rs. 100	40
Rs. 100 to Rs. 300	60
More than Rs. 300.	0

According to table 4 above, 40 out of 100 respondents save less than Rs.100 each meeting, while remaining 60 respondents save between Rs.100 & Rs.300 per meeting.

Table 5: Loan Purpose

Purpose	Frequency
Education of Their Dependents	19
Household Consumption & Improvement	09
Acquire Assets	23
Self Employment	38
Medical Treatment	11
To Repay Debts	08
Others	06

The reason of respondents' loans is depicted in Table 5. According to table, 19% of respondents took out loan for their children's education, 9% for household consumption & improvement, 23% for asset acquisition, 38% for self-employment, 11% for medical treatment, & 8% for home improvement.

CONCLUSION:-The purpose of this study is to explain current dispute over different elements that contribute to women's empowerment through microfinance programmers. Majority of recipients are in their middle years of life & have had only rudimentary education. Importance of microfinance programmers in women's empowerment is further demonstrated by review of prior studies. Political participation, mobility & freedom, economic independence, self-confidence & respect, education relevancy, protest against societal evils, & financial planning & control were discovered to be most essential variables leading to women empowerment in this empirical study. [10] Self-esteem & respect have been identified as contributors to two variables: Women are more autonomous than ever before, & they have flexibility to engage in their family company if necessary, demonstrating their empowerment. These two concerns, in which respondents feel more autonomous than previously & can make family decisions, emerged as important markers of women empowerment. Taking lead from these two might be another key aspect. Through these viewpoints, other factors group represents economic, social, & political empowerment. Microfinance programmers, in our opinion, should be aimed at giving these elements substantial boost. [11]

REFERENCES

- 1.Babajide, Abiola, & Taiwo Joseph, (2011), "Microcredit & Business Performance in Nigeria: Case of MFI Finance Enterprises", International Journal of Research in Commerce & Management, Vol. 2, Issue No. 11 (November), pp 43-49.
- 2.Desai, V. V., (2011). "Self Help Groups: Integrated Approach of Empowerment for She Entrepreneurs", International Journal of Research in Computer Application & Management. Vol. 1 (2011), Issue No. 7 (September), pp 133-136.
- 3.Henriques, Elizabeth Joey, & Rekha Ramesh Gaonkar, (2011). "Micro-Credit: Study of Micro-Credit Usage by Self Help Group Members in Goa", International Journal of Research in Commerce, Economics & Management, Vol: 1, Issue No. 3 (July), pp 56-60.
- 4.Juliet Hunt, "Reflections on Microfinance & Women's Empowerment," Independent Consultant Nalini Kasynathan, Oxfam Community Aid Abroad, South Asia, pp 20-26.

5. Kanniammal, K.; U. Jerinabi; & A. Arthi, (2011). "Impact of Micro Finance through SHG-Bank Linkage Programme On Women of Rural Priority Communities In Coimbatore District", International Journal of Micro Finance, Puducherry, Vol-1, No.1. pp. 34 – 42.
6. Khandker, R.S., (1998), "Fighting Poverty with Micro Credit: Experiences in Bangladesh", Oxford University Press, New York: World Bank, pp- 228.
7. Kundu, D. (2016). Microfinance delivery institutions in India-governance & management challenges. Journal of Commerce & Management Thought, 7(2), 278-297.
8. Nalini, S. M., Patil, S. Suresh., Loksha, H., Deshmanya, B. Jagrathi., & Maraddi, N. G., (2013). Impact of Self Help Groups on Rural Economy in North East Karnataka. Karnataka J. Agric. Sci., 26 (2) : (220-223) 2013.
9. Patel, A.R., (2002). "Rural Credit Delivery System", Kurukshetra 11 (2):4-8.
10. Rai, Kamini., (2015). Micro Financing Through SHGs Empowering Women: In Indian Context" International Journal of Management & Social Science Research Review, Vol.1, Issue.8, Feb - 2015. E-ISSN - 2349-6746, ISSN -2349- 673.
11. Ramakrishna & Murthy, Krishna., (2003). 'A Role of SHGs for Empowering Rural poor in Vishakapatnam', Discovery Publishing House, New Delhi, pp.11-16.

WORK-LIFE BALANCE OF NURSES OF SUPERSPECIALITY HOSPITALS AT HYDERABAD

Shahnaaz Sultana- Research Scholar

SJJTU- Regn No: 231218058

Email-id: shahnaazkhanum@ymail.com

ABSTRACT:-The study is about work-life balance and focuses upon the inevitable balance between the professional work and personal life. It reflects how an individual balances his/her professional and personal encumbrances. Here balance means how one feels at ease or at equilibrium with certain things like free time, relationship, family and health. It is important for women employees to manage and do justice for professional work and personal life, and in the process if they spend more time focusing on one aspect then it may lead to negative outcome. A strategic analysis of work-life balance can help an individual to perform well. An employee can excel in his/her areas if there is a proper synchronization of both personal and professional life. The objectives of the study is framed on three aspects ie, physical health, mental health and job satisfaction. These three aspects have been studied on the female nurses at specialty hospitals. It is concluded that there is lot much to be done to achieve the work-life balance of nurses in Hyderabad, particularly the stress and physical health of the nurses should be taken care.

Keywords:- work-life balance, nurses, stress, physical health, mental health.

INTRODUCTION:-Work-life balance means harmony between one's professional work and one's personal life, as a result, a good work-life among nurses means neither professional career nor the personal life overtakes the other.

Why work-life Balance Important among nurses?

Without balance in their life, nurses may become liable to illness or job burnout. If they are worn out and diverted, nurses may make medical mistakes that can harm patients. A deprived work-life balance can be a cause for higher turnover, which can direct to employment shortages and more healthcare costs.

These days, hospitals are confronted with great struggle and inadequate resources than ever before. They are also strictly challenged by the external and internal environment to accomplish their goals successfully and efficiently. Nurses' performance is an important role in shaping the quality and cost of healthcare. It is argued that they have the prospective to be part of solutions to key problems in health care systems. For this reason their roles are of importance in hospitals and in their own families alike.

Nurses struggle with work-life balance due to the nature of the job, long hours and shift work commitments. Nurses' are especially exposed because they are the most socialized caretakers, and the result is that they put other's needs before their own. Nurses should pay additional concentration to organizing work-life balance to make sure they obtain maximum satisfaction from their professional work while maintaining a healthy everyday life. Nurses' work life balance is at stake due to demand of performance and productivity from the hospitals.

The word nursing comes from root word "nutritious" means to nourish, to cherish, to protect, to support, to sustain, etc. It also means to train, to educate, to supply with the essentials of growth. Our work today as a nurse is a continuation of the work done by our parents. Nursing in its simpler form exist from time immemorial. The first mother was the first nurse that is our mother. From the time the first mother to the present day, we have found women caring their children, and pleasing care of the elderly and sick members of the family. They also render their services to the neighbors in times of illnesses.

Requirements of nurses are ever rising because of their approach in taking care of the patients which we have not seen much in other professions. Because they get back smile on the faces

of patients with their generous and commitment. therefore, maintaining them satisfied and content is of maximum value.

Health care segment is an area where one has to work 24/7, always watchful and on toes. This creates stress between nurses when they are working overtime and continually in pressure. Striking balance between work and family is important to have physical and mental health. Proper working conditions, working schedules and support from family members will help in attaining good physical and mental health.

The challenges of stress and burnout

Stress and job burnout can reason, add to, or result from a unfortunate work-life balance. They interrupt our usual patterns, behaviors, and feelings.

Barriers to balancing work and life

How to help yourself

Moving toward a better balance

More effective time management

Stronger relationships

Better self-care

One step at a time

Review of literature

Review of literature provides better understanding of the ground areas of research already undertaken and light a torch on the potential regions which are yet to be concentrated. Taken into account this, an attempt has been made by the researchers who have collected various related reviews. The reviews of some of the important studies are presented below:

Goyal K.A, Agrawal A (2015) in the paper titled " Issues and challenges of Work life balance in banking industry of India" explained that Work life balance policies and programs are an investment in an organization for improving productivity, reducing absenteeism, achieving improved customer services, better health, flexible working as well as satisfied and motivated workforce especially in banking industry.

Murthy M. and Shastri S. (2015) observed various issues in Work Life Balance of Parents in the paper titled "A Qualitative Study on Work Life Balance of Employees working in private sector", like parenting issues: Need more time for children, Showing work frustration on children. Marital issues: Need more time of spouse, not able to give time to spouse. Role conflict/ Role guilt: Doubtful about how good they are in the roles that they play at home... eg. as a mother or as a daughter in law.

Kumaraswamy M., Ashwini S.(2015) in paper titled "Challenges in WLB of Married working Women" studied that it is important for employees to maintain healthy balance between work and their private lives. Generally those employees who have better work- life balance contribute more towards the success of the organization. The organization can render better service to the customers by having productive and efficient employees. Family sphere changes that have impacted the work life balance of individuals in today's context include nuclear families, single parent households, and dual earning parents, parents working at different locations and increasing household work.

Muhamad Khalil Omar et al., (2015) in their study titled "Workload, Role conflict and work life balance among employees of an enforcement agency in Malaysia" examined the effects of workload and role conflict with work life balance among the employees. The output of the study revealed that work load act as one of the critical dominant factor which affects the work life balance followed by role conflict The work load and role conflict negatively correlated with work life balance. Higher the work load and role conflict felt employees were experiencing work life imbalance

Dr. P.Kannan & Suma.U (2015) they proved that stress in banking sector is mostly due to excess of work pressure and work life imbalance the organization should support and encourage taking up roles that help them to balance work and family.

Santosh R. S., Jain R. (2016) in their paper "Study of Effect of Commuting & Working Hours on Work Life Balance of Working Fathers in Mumbai" proved that Long working hours and long commuting hours are seriously affecting the Work Life Balance of working fathers in metro cities. There is need to research and investigate further on this subject in order to improve lives and productivity of working men in metro cities of India.

B.kishori & B.vinothini (2016) the researchers have explored the fact that decisive factor like that productivity of the work force is important for the accomplishment of an organization is concerned. They stretched out that an employee is uncovered to all types of stressors that can

Influence them on all dominion of life

Objectives of the Study:

- To identify the stress experienced by female nurses.
- To know the causes of stress among female nurses.

Research Methodology

Research design adopt for this study is Descriptive. Primary data was collected through survey method by using questionnaires. Sample of 105 female nurses who are working in multispecialty hospitals in different departments such as medical, gynaecologist unit, surgery, emergency care unit, ICU, AICU were collected. The study was pointed down to working mothers and hence purposive sampling method was adopted. Secondary data was collected from journals and Research articles.

Limitation of the Study

This study was limited only to female nurses who are working in multispecialty hospitals in Hyderabad City. Research was confined to working mothers who has more than one dependent child and as sample size of 105 female nurses was collected from different departments

Findings of the Study

The following are the analysis and interpretation of the present study conducted by this survey.

Table 1: Age Group of Respondents

age Group	frequency	percentage
22-27	18	17.14
28-32	25	23.80
33-37	27	25.71
38-42	19	18.09
Above 42	16	15.24
Total	105	100

Source: questionnaire

The above table shows that 17.1% of respondents belong to the age group of 22-27. 23.8% belong to the age group of 28-32. 25.7% belong to the age group of 33-37. 18.2% belong to the age group of 38-42 and 15.2% belong to the age 42 and above.

Table 2: Classification of nurses on marital status

Marital status	percentage
Single	59
Married	26
Widow	10
divorcee	5

Source: questionnaire

The above table shows that 59% of respondents belong to single. 26% belongs to of married. 10% belong to widows.5% belong to the divorcee.

Table3: spend quality time with family

LEVEL	PERCENTAGE
Always	15
Often	9
Sometimes	41
rarely	15
never	20

Source: questionnaire

Table shows that 15% of the respondents feel that they spend value time with their family always and 9% of them feel that they often spend quality time with family members. 41% of the respondents says that they spend quality time with their family members only sometimes, 15% of them rarely and 20% of them never able to spend quality time with their family.

Table 4: Do you do overtime and work for long hours?

always	often	sometimes	rarely	never
28	32	25	10	5

Source: questionnaire

The above table shows that 28% always do overtime and work for lengthy hours, whereas 32% of the respondents says that they often has to work for extended period. 25% of nurses are of belief that they are made to work for long hours and do overtime sometimes and 10% rarely and only 5% says that they never have to work overtime and for long hours.

Table 5: stress related problems

LEVEL	PERCENTAGE
Frequent headaches	38
Acidity	25
Mood swings	5
Hypertension	15
Diabetes	8
Any other	9

Source: questionnaire

Table 5 shows that 38 of the respondents have regular headaches, 25% of them have acidity, 5% have mood swings, 15% of them bear from hypertension, 8% of the respondents have diabetes and 9% suffer from other stress related problems.

Table 6: Do you carry out any physical activity

always	often	sometimes	rarely	never
12	15	25	23	30

Source: questionnaire

The above table shows about the physical activities of nurses from the survey we notice that the nurses do exercise and yoga as physical activity. It is evident that more than 50% of the respondents rarely or never indulge in any kind of physical activity, only around 27% of the respondents have some or the other kind of physical activity +--+

Table 7: Do you follow any nutritious diet

Always	Often	Sometimes	Rarely	never
10	14	22	24	35

Source: questionnaire

The above table we can interpreted that the nurses have nutritious diet. It is evident that more than 59% of the respondents rarely or never indulge in any kind of, nutritious diet, only around 24% of the respondents have some or the other kind of diet.

Table 8: Do you take eight hours of sleep

Always	Often	Sometimes	Rarely	never
32	16	15	22	20

Source: questionnaire

The above table show that 32% of the respondents feel they have always eight of sleep 16% speak out often, 15% of them say they are sometimes eight hours of sleep and 42% of the respondents rarely or never indulge eight hours of sleep

Table 9: Do you feel exhausted?

Always	Often	Sometimes	Rarely	never
46	15	27	12	5

Source: questionnaire

The above table show that 46% of the respondents feel they are always exhausted, 15% speak out often, 27% of them say they are sometimes exhausted and 12% of the respondents feel they are rarely exhausted.

Table 10: Importance of family support on work life balance Family support does not matter to me in balancing work-life aspect

Agree	Strongly agree	Neutral	disagree	Strongly Disagree
5	3	4	33	55

Source: questionnaire

Table shows the importance of family support in striking balance between work and family. 5% of the respondents feel that family support does not matter, 4% are neutral and 3% strongly feel that they do not require family support in balancing work life aspect. But 55% of the respondents strongly feel that family support is very essential in work life balance and 33% of nurses opine family support does matter for them in striking balance between work and family life.

Table 11: Positive effect of support from hospital authorities

Strongly agree	agree	neutral	disagree	Strongly disagree
8	25	38	8	26

Source: questionnaire

This table shows that support from hospital authorities has positive effect on Employees performance. 40% of the respondents agree that support from hospital authorities has positive impact in balancing work life aspect, 58% of the respondents feel they strongly agree in this regard and only 2% of the respondents disagree to this analysis.

Findings:

The findings of this study is to recommend to the hospital authorities to initiate in making more work-family friendly policies which will help the female nurses in striking balance between work and family.

- About 41% of respondents said that they spend quality of time with their family.
- About 8% of respondents agree that they receive positive support from hospitals and 26 strongly disagree.
- Regarding health related problems, most of the nurses suffered from various health issues and that they don't have time for physical activities, proper diet and eight hours of sleep.

Suggestions

1. Organize a Stress Management Program that focuses on different leave categories of Employees at all hierarchical level.
2. The hospital should provide some recreation facilities and also conduct yoga classes for peace of mind
3. Encourage open channel of communication to deal work related stress.
4. The hospital human resource management should adopt some strategies to balance the work and life

An employee's satisfaction to meet personal commitments affects greatly to achieve success at work. This ultimately benefits the companies. So, companies can adopt policies to promote work-life balance.

Conclusion:-The current study was conducted to know the work life balance of nurses who are working in multispecialty hospitals in Hyderabad city. Through this study the researcher was able to know the work life balance issues, stress caused in the work-life difference and the role of personal and professional life in attaining work life balance of nurses.

The study reveals that majority of the respondents has a real problem in striking balance between work and family and though many of them enjoy their work in helping people they are facing stress related health issues. Most of the respondents feel if appropriate work preparation and timely support provided by both family and hospitals they will be stress free to some extent and will be able to strike balance between work and family.

References

- 1.MK Omar, IH Mohd, MS Ariffin International Journal of Business, Economics and Law 8 (2), 52-57
- 2.Dr. **K.A. Goyal** 2012()... Volume : 8, Issue : 5, November **2015** ... Arpita **Agrawal** Babel.
- 3.Mridula N **Murthy** and Shailaja **Shastri** ... **Work-Life-Balance is** how one prioritises career and lifestyle. ... Vol. 6, **Issue**, 7, pp.5160-5167, July, **2015**
- 4.B.Kishori & B.Vinothini, a Study on Work Stress among Bank Employees in State Bank of India with Reference to Tiruchirapalli. International Journal of Management and Commerce
- 5.P. Kavitha(2012) Role of stress among women employees forming majority workforce at IT sector in Chennai and Coimbatore, Tier-I & Tier-II centres, SONA Global Management Review , Volume 6, Issues 3, May 2012

Role of Emotional intelligence in for gaining competitive advantage

Research Scholar - Tejasvita Singh

Reg. No. 28517107

Dr. Priyanka Gupta

Asst. Professor

Management

Shri J.J.T.University

INTRODUCTION

Emotional intelligence (EI) is a popular concept in social sciences. Scholars have a continuing interest in the field of emotional intelligence (Alavi et al., 2013; Karimi, 2012; Srivastava, 2013). As a result, there are as many definitions as there are people who have attempted to define it. Emotional intelligence has been defined as “the ability to perceive and express emotion, assimilate emotion in thought, understand and reason with emotion, and regulate emotion in the self and others” (Mayer et al., 2000, p 396). This definition consists of three types of abilities: (i) expression and evaluation of emotion, (ii) regulation of emotion and (iii) using emotions in decision making process. A similar definition was given by Bar-On (1997) as “an array of emotional, personal, and social abilities and skills that influence an individual’s ability to cope effectively with environmental demands and pressures”. Again, Goleman (1998) claimed that “emotional intelligence is the sine quanon of leadership. Without it, a person can have the best training in the world, an incisive analytic mind, and an endless supply of smart ideas, but he still won’t make a great leader” (p. 93). He also suggested that the most important factor that distinguishes effective leaders is not their IQ but their Emotional Quotient (EQ) (Goleman,1998).

Therefore, emotional intelligence is the ability to perceive and understand emotions, to regulate and organize emotions and, to generate and manage emotions so as to enhance thinking and promote intellectual growth. Wang, Young, and Marczyk (2011) fabricated a model reliant on four energetic part domains including care, empathy, self-organization, and social relationship aptitudes. These parts are seen as a methodology starting with the improvement of care; the ability to watch one's own direct and think about how one's emotions sway one's lead. Compassion, the ability to fathom another's emotions, was seen as the second developmental level of excited competency. The third level is self-organization, where the limits of care and sympathy were used completely to adequately manage one's emotions both eventually and in social interchanges. Finally, an individual makes social relationship aptitudes as a development to the self-organization capacity. Specifically, a truly capable individual would have the alternative to have advantageous associations and correspondences during internally charged conditions. These capacities were acknowledged to be made through social and enlightening conditions.

This model was immovably changed in accordance with integrative models (Izard, 1993) at any rate mixed model systems will all in all fuse a methodology or hierarchy of progression. Petrides and Furnham (2000) portrayed Mayer's Four-Branch model as a limit model due to the consideration on scholarly energetic limit. Petrides and Furnham (2000) arranged models of EI into only two classes: limit/information planning or quality. Property EI is stressed over the improvement of excited practices, for instance, sympathy, vehemence, and certainty, which can be seen as character factors. Quality EI considers energetic information as a character trademark that fits inside the Five-Factor Model of Personality. A segment of the character characteristics that are truly related to energetic understanding consolidate

adaptability, definitiveness, enthusiastic assessment and explanation, certainty, and stress the board to give a few models. This mixed model technique is a departure from various theories as Petrides and Furnham (2001) place energetic knowledge as a quality inside character rather than an alternate form.

An essential mixed model of EI was made by Reuven Bar-On (2006) and includes five social and energetic capacities that individuals can make to grow his/her eager knowledge. Bar-On (2006) described excited social understanding as "a cross-fragment of interrelated energetic and social abilities, capacities and facilitators that choose how satisfactorily we grasp and convey, get others and relate with them, and adjust to step by step requests." One competency is intrapersonal aptitudes which are basically the ability to appreciate, think about characteristics and deficiencies, and to impart sentiments absolutely. The accompanying competency, social aptitudes, relies upon one's ability to appreciate others' emotions and work pleasingly in a get-together. The third competency is the ability to manage one's inclination of nervousness concerning emotions. A person who has pressure the board limit can regard sentiments impartially and shield them from affecting decisions and results. Right when an individual gets zeroed in on he/she may will all in all be over-energetic and license sentiments to affect decisions and associations. Exactly when an individual has high EI in this competency, in any case, he/she can adjust to stress in a sound way and hold emotions under close limitations. The fourth competency in this model is adaptability.

The ability to conform to each condition and get-together is fundamental to being productive in the labor force. An individual can develop this breaking point by ending up being even more smart thinking and prepared to make decisions as for sentiments, anyway not because of emotions. Finally, Bar-On (2006) acknowledged that a person who developed high enthusiastic understanding would moreover have a strong sensation of mental success. This prompts the last competency of general perspective, including positive reasoning, fulfillment, and self-motivation. The Bar-On model is perhaps the most alluded to and investigated models of eager knowledge and gives a thorough definition and explanation of the abilities that can be made to fabricate a person's ability to change and manage different enthusiastic conditions (Leedy and Smith, 2012; Mayer et al., 2008; Reiff, Hatzes, Bramel, and Gibbon, 2001; Sparkman et al., 2012). Eager information research has been overwhelmingly occupied with the business and the board field.

As high level training foundations focus more on work-planning, it is ending up being clear that enthusiastic information is a thought that should be discussed. Inside high level training, research has been fixated on the perceptive limit of eager information as per scholarly increments, assessments, and understudy accomplishment. Energetic Intelligence and Higher Education Research has shown that enthusiastic understanding is basic to the headway of understudies and academic achievement. Achievement in adulthood is dependent upon mental fitness, insightful limit, and the ability to keep up strong associations and direct sentiments.

As Psychologists partition the overall insight into more explicit insights which speaks to the particular capacity of that specific gathering (Catell, 1963, Guilford 1967, Sternberg, 1988, Thorndike 1920 and Wechsler 1987). Perhaps the main characterizations of knowledge was social insight and useful knowledge (Mayer and Salovey, 1993). Further the social knowledge is sub-isolated into two extents for example passionate knowledge and persuasive insight (Mayer, 1996). Persuasive knowledge is identified with the better comprehension of the inspirations for an individual, for example, the requirement for accomplishment or force and defining the objective dependent on these inspirational elements (Wagner and Sternberg, 1985 and Cantor and Kihlstrom, 1987). Enthusiastic knowledge then again center around recognizing the feelings which are affecting the

dynamic of an individual and handling the overall feelings into critical thinking abilities (Salovey and Mayer 1990).

There were two considered schools for "Enthusiastic insight" – the traditional school have an assessment that feelings are disordered movement (Salovey, 1990), additionally think about feelings as intense unsettling influence (L.F. Schaffer 1940) which further added that feelings are emerging in the individual since absence of powerful change with the climate. Anyway the another way of thinking (otherwise called current considered school) have an assessment that feelings rather than catholic and aimless, proposed that they are the essential inspiring powers (R.W. Leeper, 1948). Indeed the cutting edge hypotheses of feelings likewise consider feeling as an instrument to make the individual versatile towards the changing workplace (G. Mandler, 1975 and H.A.Simon 1982). Since each association needs to perform in a way that is better than their rival and versatility towards changing climate assumes an imperative job in acquiring the upper hand (Brenda Scott-Ladd, 2004). The job of passionate knowledge in unavoidable in any type of association whether it is a little firm or the large association yet EI turns out to be more unmistakable in the event of administration industry as it includes a larger number of individuals as opposed to actual products (Don Chrusciel, 2006), in this way enthusiastic insight assumes a crucial part in managing with the representatives as well as in dealing with the client prerequisite and managing them.

Passionate Intelligence and inventiveness both are needed by the association for making it versatile towards the change and adds touch of salt in the dynamic cycle to make the association more serious. A portion of the examination concentrates likewise upheld that correct hitting on enthusiastic insight can trigger the sidelong intuition in the association (Zhou and George, 2003). Anyway numerous associations actually has confidence in doing the things in a pre decided way, the pioneer likewise impact and control the conduct of people in a foreordained and safer manners to achieve the particular target. Yet, the presence of tempestuous climate powers the association and pioneers to adjust horizontal reasoning and find better approaches to played out the assignments and achieving the particular goals. As it additionally contended that each pre decided way can possibly be improved or supplanted or making it more favorable to the association, which necessitates that each pioneer should utilize the parallel technique for intuition in the association. This will likewise helps the association in building inspired and serious groups of people which at last outcomes in the gradual seriousness of the association (Woodman, et al., 1993).

Also in the investigation directed by Goleman (1998) found that however pioneers can be assorted as far as their initiative style yet shares some regular qualities of mindfulness, sympathy, inspiration and compelling relational abilities. The passionate cosmetics by the pioneers is sufficient to move individuals for achieving the hierarchical goals. Goleman (1995), portrays that EI has following measurements Knowing's one feelings, the executives of feelings, propelling self as well as other people, perceiving feelings in others and relational ability for taking care of relations. Taylor et al. (2008), expressed that conduct related and passionate knowledge were the attributes for the viable initiative and furthermore fundamentally essential to the fruitful administration. In managing relational climate, it was closed by the Antonakis et al. (2009), that the authority is inalienably enthusiastic and EI is a necessary piece of the initiative cycle.

Being the job of EI is inescapable in cycle of dynamic, Sevdalis et al. (2007), noticed that albeit observationally it

CONCLUSION

The significance of the connection between initiative, administration styles and passionate knowledge has been explained in George (2000), Goleman (2000, 2003), Holian (2006) and

Boyatzis et al. (2013). These postulations have unequivocally demonstrated Emotional Intelligence to be fundamental and surely be a sine qua non of administration. Per, Bass (1990), on a large scale level, the authority style can either be groundbreaking or value-based. The groundbreaking chief is more helpful, compassionate, inspiring, versatile and finds a way into the Affiliative, Visionary Democratic, Pacesetter and Coaching authority styles depicted by Goleman (2000). The Commanding or Coercive initiative style then again, is a bipolar value-based style which guarantees prizes for acceptable conduct and discipline for terrible showing. These styles have been summed up in Figure 1 adjusted from Preston et al. (2015). The fundamental highlights of a genuinely clever pioneer are likewise depicted by Goleman (2003), of which, mindfulness, self-guideline, social mindfulness and sympathy are the ones which will be the focal point of examination in this paper.

REFERENCES

1. George J. M. (2000). Emotions and Leadership: The Role of Emotional Intelligence. *Human Relations*, 53-1027, DOI: 10.1177/0018726700538001.
2. Gill, R. (2002). Change management--or change leadership? *Journal of change management*, 3(4), 307-318.
3. Graetz, F. (2000). Strategic change leadership. *Management decision*, 38(8), 550-564.
4. Grant, Anthony, M. (2007). Enhancing coaching skills and emotional intelligence through training. *Journal of Industrial and Commercial Training*. 39(5): 257-266.
5. Hadizadeh A., Moghadam, Tehrani M. and Amin F. (2011), Study of the Relationship Between Emotional Intelligence (EI) and Management Decision Making Styles. *World Applied Sciences Journal* 12 (7): 1017-1025, 2011 ISSN 1818-4952.
6. Harrison, Y., & Horne, J. A. (1996). "High sleepability without sleepiness". The ability to fall asleep rapidly without other signs of sleepiness. *Neurophysiologie Clinique/Clinical Neurophysiology*, 26(1), 15-20.
7. Huy, Q. (1999). Emotional capability, emotional intelligence, and radical change. *Academy of Management Review*, 24 (2), 325-345.
8. James D. Hess, Arnold C. Bacigalupo, (2011). Enhancing decisions and decision-making processes through the application of emotional intelligence skills. *Management Decision*, 49 (5), 710-721, <https://doi.org/10.1108/00251741111130805>
9. Lam, L. and Kirby, S. (2002). Is emotional intelligence an advantage? An exploration of the Learning. *The journal of social Psychology*, 12 (2), 66-77.
10. Leeper, R. W. (1948). A motivational theory of emotion to replace emotion as disorganized response. *Psychological review*, 55(1), 5.
11. Maree, J.G. and Finestone M. (2007). The Impact of Emotional Intelligence on Human Modeling Therapy given to a Youth with Bipolar Disorder. *International J. Adolescence and Youth*, 13, 175-194

THE CASE FOR CATHARSIS

Tanu Puri, 17219076

Research Scholar, Management,

Shri Jagdishprasad Jhabarmal Tibrewala University

INTRODUCTION & HISTORY OF CATHARSIS

Once defined as ‘The purgation of pity and terror in theater audiences’ by Aristotle in Third Century B.C. The word terror referred to the emotion of fear but the word pity was not a specific emotion ... it suggested empathetic identification with the characters in the drama. He wished to define it as the emotional reactions of audience to the drama which eventually turned into a narrow domain. He insisted that catharsis in drama is not only a source entertainment and pleasure but also a necessity for the survival of the concept of society.

Centuries later, cathartic method came back to life when Breuer and then Freud started using it to treat severe hysterical symptoms of patients under hypnosis. Breuer came across cathartic technique by chance that worked with little effort from him. Patients seemed to have an emotional release which, if uninterrupted, proved therapeutic. Catharsis was explained by the term ‘Abreaction’ as defined by Freud and Breuer. Abreaction in their words was “The whole class of voluntary reflexes, from tears to acts of revenge, in which as experience shows us, the affects are discharged. If this reaction takes place to a sufficient amount a large part of the affect disappears as a result.” They explained it further- “ If the reaction is suppressed, the affect remains attached to this memory. An injury that has been repaid, even if only in words, is recollected quite differently from one that has had to be accepted...the injured person’s reaction to the trauma only exercises a completely cathartic effect if it is an adequate reaction as revenge, But language serves as a substitute for action, by its help an affect can be abreacted almost as effectively.”

This was later used in the emotive therapies of the seventies like Re-evaluation counselling (developed by Jackins), Gestalt therapy (developed by S.Perls), Psychodrama (developed by Jacob L. Moreno), Primal therapy (developed by Janov) , New Identity therapy (developed by Casriel). But when Freud finally abandoned ‘the Cathartic Method’ to treat his patients it was not because he believed catharsis was a failure but because he had found a much more reliable tool- free association. This is often misunderstood as catharsis proving out to be an ineffective tool on account of which it was given up by Freud. Yet it is to be remembered that he was never an emotivist. He believed that affect was associated with the resurrection of traumatic or repressed memories so instead of going the ‘cathartic way’, he later chose to go ‘the memory way’ that is, he chose the cognitive tool of overcoming repression with the help of free association. His emphasis on free association de-emphasized the role of catharsis. The emotive therapies, on the other hand, were developed solely on the basis of catharsis. They believed that emotions are stored in the mind or body that need to be released after which they bring respite to the individual. They found expression of emotions to help with the reduction of and relief from psychological issues.

Along came the studies in experimental social psychology that produced large body of research *against* the notion of catharsis wherein aggression catharsis increased aggressive

behaviour instead of reducing it and vicarious aggression (viewing or participating in vicarious violence) also resulted in increase of hostility in individuals.

One ponders the cause of the difference between the clinical and experimental findings. The clinical findings of Breuer, Freud, Jackins, Janov, Casriel stand opposed to the experimental findings of Berkowitz (1962), Feshback & Singer (1971), Quany (1976). Where the experimental findings point towards increase in hostility instead of reduction, clinical findings suggest otherwise.

Breuer, Freud and emotivists like Jackins, Janov referred catharsis as the repressed affect that finally sought discharge in consciousness with the help of the therapist. What behaviourists called catharsis is artificial emoting of affect and sometimes, thoughts under the tutorship of the therapist who provokes certain kind of responses in order to provide relief. Here, the objective of the therapy would be venting or 'acting out' or 'Behaviourizing' of aggression or any other emotion. It appeared to have palliative effect on the individual suffering from a psychical trauma. However, it was noticed to be short lived. Angry yelling or pressured crying does not come naturally in such sessions. Because it is supposed to be a session where discharge of emotions has to take place, the person is expected to emote. Whether he wants to or not in that moment is not of primary importance. It is simply believed that left over or retained affect is what causes the distress to the individual in question and it, therefore, must be discharged.

Catharsis was somehow treated by emotivists as if a human was a carrier of these emotions that needed to be released. In fact, the language of emotions came close to the language of hydraulics. Sadness 'wells up', grief comes in 'waves', anger 'boils'... emotions were understood as causes of one's ailment and only expression of those emotions were seen to help in temporary or permanent respite. Gradually, emotive therapies like Re-grief therapy or Feeling therapy became only about expression of emotions under the tutorship of the therapist whether or not, there really was enough inside to be released. Verbalized repressed affect, which was the sole motive of catharsis, turned into emoting anything and everything, whether or not there was any repressed affect that needed to be released. The emotive therapies first shaped into the channels for verbalizing affect and then into spaces for verbalizing thoughts. The distinction between affect and thoughts dissolved letting the thoughts take hold of the emotions. Emotions under the influence of thoughts cease to be passive drivers of behaviour and end up becoming active determinants of behaviour. This is one of the reasons why experimental social psychology has produced large body of research against the notion of catharsis wherein aggression catharsis increased aggressive behaviour instead of reducing it and vicarious aggression (viewing or participating in vicarious violence) also resulted in increase of hostility in individuals.

As observed, there are two different concepts that are referred here by the same name- the process of catharsis. And catharsis has been accused of, by way of experimental findings, to lead more aggression rather than less of it. Perhaps this is the reason why clinical findings oppose the results derived from experiments...because both revelations refer to two different concepts using the same name. And yet, they share one more thing besides the name. They also share the concept of emotions. Affect is what is common to both exponentially contrasting ideas of catharsis. Both require discharge of emotional tension. So in order to save true catharsis from further misrepresentation, one has to begin from the basic notion of emotion. Only when the construct of emotion is understood, the difference in the two distinct concepts of catharsis can be appreciated.

EMOTIONS

Scheff (2007) explains that angry yelling does not count as a reflex like a spontaneous crying or laughter or any other involuntary reaction. He insists that aggression catharsis is a complex sequence of external behaviour and not a reflex. According to him, catharsis happens when emotional climax or orgasm is reached. This is similar to what Breuer and Freud pointed out in terms of abreaction and its definition. In their point of view, catharsis can only come along when there is a voluntary reflex to discharge an affect. They also explain an injury which if un-suppressed needs an adequate reaction to bring about a cathartic effect but if suppressed attaches itself to a memory which can at best be 'talked out' as a fair substitute to the original reflex. In so many words, the early thinkers of the concept have laid the foundation for the case for catharsis that can help a reader to differentiate between catharsis and voluntary, provoked action which is more often than not confused with catharsis.

To understand it better, one can look at Newton's third law- 'Every action has an equal and opposite reaction.' Now catharsis has much to do with it. When Freud & Breuer explained catharsis, they spoke about reaction. Any reaction takes place against an action and it has to be of equal force. The action in this case is the stimulation and the response (the reaction) is made up of impulse, perception, manipulation and consummation (Scheff, 2007).

- Impulse is the drive generated as the first response to the stimulus. It is raw in nature- untamed & instinctual.
- Perception is the awareness and understanding of the impulse risen in the mind of the individual.
- Manipulation is assessment & evaluation of the right action with regards to the object or stimulus.
- Consummation is the employment of the chosen action in order to satisfy the original impulse.
- Together these four process stages initiate the process of emotion. The emotional arousal begins with the birth of the impulse and ends with the consummation of the action employed in order to satiate the impulse generated in response to the stimulus.

As such, emotions last until the impulse is satisfied, that is, until the equal and opposite reaction against the action (stimulus) has been achieved. Once the emotional orgasm or climax has been attained, the emotional arousal decreases to zero within seconds and the emotion comes to an end. All arousal need to reach their climax. If they are interrupted, they attach to the memories and stay as affect or emotion without finding their orgasm or discharge. An emotional sequence, once initiated, must come to a completion. In the case of long lasting emotions like love or hate, the emotional sequence starts but approaches its zero arousal infinitely slowly.

It is the interruption in the sequence of emotions that causes retention of affect within the individual thereby attaching it to the memories of the event that acted as the stimulus for the emotional sequence to initiate. This affect, so attached to the memories, awaits to be discharged as Freud pointed out. Unless the emotional sequence comes to its natural end and the consummation is attained, the climax remains out of reach. The action occurred but its equal and opposite reaction failed to transpire. The experience or the event in the mind of the individual, to the memory of which the undischarged is now attached, ceases to get over. The individual keeps reliving under the stimulation of various associations. What Freud did by making use of 'Free Association' as a cognitive tool was to uncover these associations to reach the core memory of the experience that failed to materialize. On reaching the goal-memory with the help of the thread of associations, the traumatic experience is re-lived by the

patient/client. Words and language often act as a proper substitute to actions. The repressed memory finally gives way to the original interrupted emotional sequence, final consummation of the reaction (to satisfy the impulse against the stimulus) takes place and catharsis is reached.

Thus, emotion is nothing but the sequence of the reaction against the action, interrupted. If it were not discontinued or stopped, there would be no affect. It would simply be a response to a stimulus, a reaction to an action. A halted or broken sequence of response to a stimulus is what gives rise to the concept of emotions.

Pain or any emotion, thus suppressed needs to be felt. An emotion is simply a response left suspended without reaching fruition. What Breuer and Freud called abreaction was the completion of these voluntary reflexes which remained suspended due to repression. This is the concept of catharsis which was found and then later abandoned by Freud in order to use 'Free Association' in psychoanalysis. True catharsis occurs when the repressed affect is let out in the same way it was earlier meant to. It should be as voluntary in the current circumstance as it was when it was first repressed. However, the experimental findings could not study these reflexes or voluntary reactions in the form of suppressed affect. They turned out to be useless in the face of identifying between an interrupted emotional sequence and artificially generated emotional reactions as in the case of aggression catharsis or vicarious aggression. These laboratory studies could not differentiate between an unmaterialized impulse and a provoked response. The experimental studies could only calculate the tutored responses under controlled situations. There was never true catharsis that was ever brought under the experimentation and what is an experiment after all? A good experiment can always be replicated. However, emotions can never be replicated; no two humans will ever have the same emotions in the same intensity at the same time. The clinical findings can therefore be justified but experiments done on emotions do not provide trustworthy results.

Some emotions have certain specific stimuli. These can also be called triggers. They instigate the response which if left incomplete give rise to feelings. An emotion like grief has a stimulus in loss; fear has a trigger in external or internal danger; anger has a stimulus in frustration and shame or embarrassment is triggered by threat to bond. If only grief was not stopped when it was, one would not need to grieve or find its manifestation in some expression later. Grief over something implies loss; a loss that needs to be mourned. It just so happens that if someone grieves over a loss of a dog for more than two years, his relatives tell him to move on. But it is important to note that his mourning is not over. He is done accepting the loss. His psyche still looks for the lost object. Time is an element which many people factor in the process of grieving when it especially should be kept out of the equation. Loss is loss. Big or small object should not matter but unfortunately, in today's world it does. Pain needs to be felt. It demands to be felt. It is a warranted reaction to an equal and opposite action that has already taken place. Because if it isn't acknowledged, it will find a way to come out and make its presence felt. More often than not, it comes out as symptoms.

If any danger was simply allowed to fear from, it probably would not materialize in the way of some unusual symptom. But whether it is an external danger or an internal one, an individual is usually advised to 'pull it together'. When he is unable to, he is referred to some kind of therapy. For instance, if an adult has intense fear of spiders since childhood such that he cannot be in the same room if he senses there is a spider present, he is called to have Arachnophobia. In such a case, he is usually referred to some kind of therapy but one wonders if there is just an undercharged and interrupted emotion which overtime has accumulated, accentuated and evolved because there definitely must have been an action that

triggered the said phobia for the child who, as an adult, is still terrified of spiders. Perhaps there is a reaction that remained suspended and retained as an affect, attached to a memory, which only needs to be discharged in a cathartic way.

Similarly, when a need or a wish is frustrated, it can lead to anger. But when this anger is not permitted to come out, it stays. Sometimes, with time this anger turns into a feeling of disappointment. It is the opposite of climax- an anti-climax which, due to the failure in discharge, changes its quality of active, excited anger to passive dissatisfaction and dejection. However, the original quality of this discontentment remains the same- anger. The retardation in release of the initial reflex to the stimulus of need or want caused by frustration settles down in an individual's psyche and looks for an expression in any way possible thereby resulting in distress.

Along the same lines, there is the emotion of embarrassment or shame which is caused by a threat to bond. The action or stimulus in this case is the fear of being an outcast. The bond shared with one's group is threatened. An individual's, due to some unfortunate accident, ends up feeling that he would not be able to belong to the same class anymore. His identification with others comes under risk and there is a credible fear in him losing the association & inter-relation with them. His sense of belongingness faces peril. The certainty that he used to enjoy till now with his peers is at stake. The embarrassment is the resultant of the dis-similarity gained on account of an event that weakens one's bond to his peers. The foremost reaction to the threat to bond is hiding. When a person develops severe allergic rash on his face, he is only embarrassed if he goes out in public. As long as he stays inside his room without coming in sight of others, he hardly ever feels shame over his allergy. It is only when he perceives that he is being looked at by others, does he feel different from them. This sense of being different is what causes him embarrassment. However, if the initial response to the stimulus of fear of being different is allowed to take place, the embarrassment ceases to exist. In this case, if the person takes his time to hide and to prepare himself to face others; there would not be a sense of shame because he would be prepared to tackle the situation. Only when he does not have the time to prepare himself for the unexpected event which might threaten his sense of social inclusion does he feel embarrassed.

INTERFERENCE WITH DISCHARGE

As a society, as the researcher observes, we have been brought up with the notion that the only way to stop having distress is by stopping the process of distress altogether. In order to stop suffering, it is believed that if the expression of pain is brought under control the goal is achieved. However, the same is not true for good emotions like happiness. If you are happy, one is expected to express it unequivocally; sometimes even after the emotion ceases to exist. Thus, interference with discharge of an uncomfortable emotion has become a common practice in our society. If an infant cries, he is coerced into stopping. Once he stops, the care-givers feel that they have succeeded in providing comfort to the baby. Children are not permitted to cry; boys are not allowed to cry as, owing to their gender, it is perceived as a sign of weakness and it is not acceptable of girls to cry since it expresses their protest and anger. When there is always suppression waiting on the other end, an individual conditions himself to repress his emotional distress on his own. In other words, when his emotional expression of any uncomfortable (to his care-givers) kind is met with resistance, he understands that it is not welcome outside. Moreover, if it is met with punishment then it cements the idea of repressing his emotional discharge for fear of some manner of punishment. In time, this behaviour of controlling one's expression of distress is over-learned and the boy forgets to cry & the girl forgets to express her anger, except under extremely provocative circumstances.

On account of continuous inter reference with emotional expression, by others or oneself, a person accumulates a great amount of repressed emotions. Repressed sensations and feelings get accumulated in the form of bodily tensions which may go unidentified. They remain and collect gradually in such a way that it is usually hard to recognize. Over a period of time, they may sometimes shape into tangible bodily pains with no reasonable organic source. Nevertheless, it is the frustration of the completion of emotional sequence (impulse, perception, manipulation and consummation) or emotions that causes the tension instead of healthy discharge.

If there is an emotional sequence that is meant to take place as a reaction to an action and it is interfered with & the consummation of the intended action on original impulse is unable to pass, it remains as a suppressed reaction and gets attached as an undischarged affect to the memory of the event which created such a reaction in the first place. As Freud pointed out, we, as a society, are supposed to tame our impulses so as to remain civilized. Civilization is based on the foundation of controlling one's desires for the accomplishment of the greater good. The restraining of one's urges leads to frustration. This frustration either stays inside individual as unreleased affect, born out of the frustrated drive, or gets thrown out in some way. When it stays inside the person, it manifests itself in various ways; it plays some role in the person's life- either by way of organic pains or by way of mental obstacles. Unjustified anxieties, depression, fear etc. control one's life's choices, decisions and sentiments. The undischarged & frustrated impulses hold people hostage; such impulses turn out to be the cause of mental pain.

On the other hand, when these repressed impulses are able to find expression by way of words or meaningful action, they find a channel to ultimately achieve the consummation stage of the emotional sequence. The equal & opposite reaction to a triggering action is able to find completion when the affect attached to the memory of the action discovers a way out. Therefore, it is not simply the manifestation of any emotion that relieves a person of his undischarged affect but it has to be the same repressed affect that must be channelized out- in terms of words and/or actions. True catharsis occurs when the suppressed emotional sequence finds an expression. Many research studies have concluded that its participants ended up more angry after yelling or emoting their anger after a controlled instigation. However, this concept itself is flawed because catharsis happens when a frustrated reactionary emotional sequence finds an expression; not when a response is provoked under experimental settings. That is not true catharsis. It is a tutored response to an action. Here, no part of emotional sequence was suppressed. In fact, there was a channel provided to vent out. It is important to note that venting out an irritation is not catharsis; although it might prove to be cathartic for some under the right circumstances.

CONCLUSION

Thus, it can be seen that catharsis is a complex process of channelizing the affect already stored in the body by way of memories and emotions. No true catharsis can have an opposite effect of increased anger. The frustration, build up over a long period of time, is able to find a source to reach an expression of change in its quality. With this in mind, experiments that have shown that emoting a certain negative emotion can lead to increase in the same emotion is a different concept than the concept of true catharsis. Perhaps, it will be beneficial for the social scientists to further the studies into the true nature of catharsis instead of using the term as a label for any kind of expression of a pent-up emotion.

THE ACCOUNTING PRACTICES IN BUSINESS OF WEST BANGAL

MANOJ KUMAR ROONGTA AND DR. MADHU GUPTA
RESEARCH SCHOLAR AND RESEARCH GUIDE, SHRI JJT UNIVERSITY,
JHUNJHUNU

ABSTRACT-The development of accounting practice in India has largely been influenced by the practice in the United Kingdom. No regulatory body is specifically responsible for the establishment of accounting principles. In several accounting areas, mandatory requirements for accounting practices are included in the Companies Act. The Institute of Chartered Accountants of India (ICAI) has during the last few years issued the following accounting standards and guidance notes. The accounting in the past was restricted to the record keeping but today it covers a wide range of activities involving business planning and control, decision making, problem solving, performance measurement and evaluation, co-ordinating and directing auditing and tax determination and cost planning and management, etc.

Keywords:- Accounting Practices, Accounting

INTRODUCTION-In today's business environments accounting practices play a significant role in arriving at overall result at the end of the year. Earlier, accounting was restricted to book keeping only but in today's scenario accounting covers a wide range of activities, including business planning and control, problem solving and performance evaluation and measurement. Progress and prosperity of business depend upon adoption of proper accounting practices. For a business to survive in the competitive era, accounting contributes significantly, irrespective of the period it reveals to. But most businessmen give less attention towards accounting of their business transactions. They usually concentrate more on selling and buying of their products and this has been more in the case of wholesale and retail businesses. Further, the transactions have increased enormously over a period of time in number and value and therefore chance of profit-making have also risen. A worthy business enterprise looks at profit, not as a transaction wise proposition but looks at it as an annual result of business efforts. Of late, customer's expectations have risen and so have the variety and quantity of goods to be stocked for sale. The sale of products on credit is part and parcel of wholesale and retail business. Investment increases in direct proportion to stocks and credit while profit rises in direct proportion to the risk borne. In addition, it is very difficult for individuals or group of individuals to keep track of each and every event and transaction of the businesses during a particular period.

Accounting Standards

AS 1: Disclosure of accounting policies. • AS 2: Valuation of investors. • AS 3: Changes in financial position. • AS 4: Contingencies and events occurring after the balance sheet date. • AS 5: Prior-period and extraordinary items and changes in account policies. • AS 6 Depreciation Accounting • AS 7 Construction Contracts (revised 2002)" • AS 8 Accounting for Research and Development • AS 9 Revenue Recognition • AS 10 Accounting for Fixed Assets • AS 11 The Effects of Changes in Foreign Exchange Rates (revised 2003), • AS 12 Accounting for Government Grants • AS 13 Accounting for Investments • AS 14 Accounting for Amalgamations • AS 15 Employee Benefits (revised 2005) • AS 16 Borrowing Costs • AS 17 Segment Reporting • AS 18 Related Party Disclosures • AS 19 Leases • AS 20 Earnings Per Share • AS 21 Consolidated Financial Statements • AS 22 Accounting for Taxes on Income. • AS 23 Accounting for Investments in Associates in Consolidated Financial Statements • AS 24 Discontinuing Operations • AS 25 Interim Financial Reporting • AS 26 Intangible Assets • AS 27 Financial Reporting of Interests in Joint

Ventures• AS 28 Impairment of Assets• AS 29 Provisions, Contingent Liabilities and Contingent Assets•

REFERENCES

REFERENCES

- 1.C. Maria (2007). Influence of Global Financial Crises on Accounting Policies, Babes Bolyai University and Faculty of Economics and Business Administration.
- 2.Ian, M. D., et al, small manufacturing enterprises, Oxford University Press, 1987.
- 3.J. Hegarty and F. G. (2004). Implementation of International Accounting and Auditing Standards. Lessons Learned from World Bank Accounting and Auditing Report on observation of standards and codes program.
- 4Karim, et al (2005), “Determinants of IAS disclosure compliance in emerging economies: Evidence from exchange-listed companies in Bangladesh”, Working Paper Series, Working Paper no. 21, Victoria University of Wellington, New Zealand.
- 5.Kumar, et al (2008). Voluntary Accounting Disclosures by U.S.-Listed Asian Companies. *Journal of International Accounting Research*, 7 (1): 25-50
- 6.S. K. James (2006), “Effective Working Capital Management in Small and Medium Enterprises (SMEs)”, *International Journal of Business and Management* Vol.6 (9), pp. 271-279.
- 7.Trombetta, et al (2004). Disclosure Interactions: Accounting Policy Choice and Voluntary Disclosure Effects on Cost of Raising Outside Capital. *Accounting and Business Research*. 33. 10.1080/00014788.2003.9729646.

EVALUATE THE PURCHASING BEHAVIOUR IN PHARMA INDUSTRY

PHATAK KETAKI MOHAN, DR. MADHU GUPTA AND DR. SHEETAL DAREKAR
RESEARCH SCHOLAR, RESEARCH GUIDE AND RESEARCH CO-GUIDE,
SHRI JJT UNIVERSITY, JHUNJHUNU

ABSTRACT-Digital marketing is open idea which considers necessities and medical care wants of all partners included, that incorporates online local area's association and offers patient's perspectives and encounters. There are applications to actually take look at impact of treatment on persistent. Unique client insight and now and again, deficient handle over client assumption, high preparing and once again preparing cost of clinical staff, lesser time given by specialists to deals call because of feverish timetable, deceptive practices embraced by some Pharma organizations prompting expanded contest.

KEYWORDS- PHARMA, AGAIN, STAFF, MANAGEMENT.

INTRODUCTION-With the progression of innovation, customers' assumptions have transformed, they need to know about all that is going on with their wellbeing on single tick, to stay aware of the speed of customers' prerequisites that incorporates the specialists and the patients as well as all the partners in question. Pharma organizations have moved up to digital marketing methodologies from the previous conventional techniques. In the customary procedure every one of the exercises moved around the Medical delegate and the specialist. Clinical Representative is the one addressing the Pharma organization and elevating the prescriptions to the specialists, with the help of limited time information sources and systems arranged by the marketing division. Conventional marketing procedures has limits that empowered the examination for digital marketing systems getting utilized in the Pharma Industry as contemplated in the accompanying exploration.

Outline of Pharmaceutical Industry in India

The Pharmaceutical Industry is top most science and exploration base industry in India that arrangements with combining drugs and related innovations. It fabricates pretty much every sort of medication going from basic ones for normal sicknesses to exceptionally complex mixtures for cardiovascular problems and other immunological issues. drug industry of India positions third on worldwide level regarding volume and with respect to value. deals of Indian drugs expanded by CAGR of 17.7 % to US\$ 34 billion in year 2016. It is relied upon to grow at CAGR of 23.10 % to accomplish US\$ 56 billion by year 2020. This will make Indian Pharma Industry as 6thlargest market in world. Indian pharma market has extraordinary potential for development. industry gets the job done around 72% of interest for homegrown market's different medications. center of drug industry of India is shaped by roughly 252 enormous and 8100 limited scope units. Drugs in India has developing per capita deals which provides bountiful freedoms for rivalry in this market. Further, India has labor force that is talented and alsohas administrative and specialized capability that is high, when contrasted with others in Asian mainland. cost of creation in India is right around 34 % lower when contrasted with US. Combined with less expensive expense of work, cost of building fabricating plant for creation is around 42 %lower in India than in Western nations. Indian biopharmaceutical modern area that significantly incorporates immunizations, therapeutics and diagnostics adds to around 63 % of complete income. Some of significant Indian Pharma companies are Aurobindo Pharma, Dr Reddy's Labs, Sun Pharma, Ranbaxy, Cipla and so forth These organizations have their auxiliaries in different nations, for example, US, UK, Germany, South Africa, Brazil, China, Australia and so forth There has been developing interest of Indian Pharma organizations towards improvement of new medications and in year

2010, clinical preliminaries for around 13 new medications were led by top Indian organizations.

Industry has likewise made ventures to develop drug and medical services advertise and work on its quality. Industry is investing amounts of energy in becoming exploration driven just as fare arranged undertaking with worldwide presence that is equipped for giving immense scope of value items and administrations with high worth expansion.

Existing marketing procedures

Pharma marketing or medico marketing is significant idea through which drug organizations publicize their items for working on their deals. Normal devices utilized by medical organizations for marketing their items incorporate item tests, logical information, giveaways identified with items and Cme's.

Pharma industry executes two sorts of methodologies: pull and push procedures for expanding deals. Push methodology where individual selling drug is focal or significant for promoting item through marketing channel, for this situation salesman/clinical agent having place with specific drug organization. Push methodology rotates around clinical delegate and specialist. Clinical Representative is implementer of methodologies planned by marketing office towards developing propensity for endorsing item/brand in Physician. Salesman offers plenty of special data sources like pens, mugs, schedules and numerous other limited time contributions to Physician as arranged by marketing office to build deals. In customary, that is existing marketing, the two deals and marketing are two separate elements, culture is traditionalist, sales reps need to stringently follow techniques set somewhere near marketing office, despite the fact that occasionally salesmen may not be agreeable or persuaded with same, sales reps are more down to earth in approach than marketing individuals, both marketing and outreach group in significant number of pharma venture are not synchronized together. Additionally, now and again salesmen can't execute techniques way they ought to be, as imagined by marketing division, this prompts disappointment of methodologies and income misfortune. Digital techniques vary here, as is thinking about assessments of every one of those involved and isn't completely subject to salesmen for execution of systems. Ordinarily contact is immediate among organization and doctors, along these lines have limitless freedoms to dominate. On other hand, pull procedure joins broad publicizing and deals advancement to get item through different channels of marketing. primary point of pull procedure is to create such lot of mindfulness in shopper that the individual requests that specialist endorse that medication. Writing shows that frequently patients ask straightforwardly for vigorously publicized medication. This should be possible for both over counter medications just as professionally prescribed prescriptions. Nonetheless, accomplishment of pull technique isn't exceptionally clear as everything relies upon Physicians, in case they are persuaded with brand proposed by patients.

They might want to go with their routine endorsed items. Drug organizations are carrying out the two systems to support their sales, however it is as yet indistinct which strategies are best for purpose of buyer.

REFERENCES

1. Armstrong, G., Kotler, P., Harker, M. & Brennan, R., 2015. Marketing: an introduction. s.l.:Pearson Education.
2. Bryman, A., 2015. Social research methods. s.l.:Oxford university press.
3. Cohen, L., Manion, L. & Morrison, K., 2013. Research methods in education.
4. Creswell, J. W., 2012. Qualitative inquiry and research design: Choosing among five approaches. s.l.:Sage publications.
5. Creswell, J., 2013. Research design: Qualitative, quantitative, and mixed methods approaches. s.l.:Sage publications.

6. Flick, U., 2015. *Introducing research methodology: beginner's guide to doing research project*. s.l.: Sage.
7. Hennink, M., Hutter, I. & Bailey, A., 2010. *Qualitative research methods*.
8. Hernández, B., Jiménez, J. & Martín, M., 2010. Customer behavior in electronic commerce: The moderating effect of e-purchasing experience. *Journal of business research*, 63(9), pp. 964-971.
9. Hooi Ting, D. et al., 2011. Dependency on smartphone and the impact on purchase behaviour. *Young customers*, 12(3), pp. 193-203.
10. Jackson, S., 2015. *Research methods and statistics: critical thinking approach*.

PIONEERING INNOVATION

Saniya Afzal Research Scholar, JJTU University, Chudela, District – JhunJhunu,
Rajasthan State, India.

E-mail : saniya_biyabani@yahoo.com

ABSTRACT :-Pioneering innovations is a specialist innovation business consultancy whose mission is all about taking great ideas to market. Develop an innovation Strategy, Generate profitable intellectual property, Obtain innovation funding, Turn new ideas into Profit Access to finance Grants, Business angel and venture capital finance are the lifeblood of early stage ventures - BUT it takes a lot to convince people to invest in you. Whether you need help with business planning, grant applications or pitching for finance. We can help you to. 'Build a stronger case for investment'. Attract new sources of finance, Get R & D Grand equity funding market and business Development even the very best run businesses can benefit from a fresh perspective to develop strategies and plans for faster growth, We can help you achieve better results through improved, Customer research. Market insight and analysis, Sales & Marketing Strategy development.

INTRODUCTION:-Pioneering innovations is often the example of innovation most associated with the terms innovations. Pioneering innovations occurred when brand new products, service or way of doing something is introduced into the market. This method However is the rarest form innovations as most product services already been introduced into the market in one form and another. While not every industry may have utilized each innovation is very rare that a new product service or way of doing something is completely original. When I think of pioneering innovations, I think of invention is something that is brand new and refers to the very first occurrence for example Thomas Edison is widely known as the inventor of the light Bulb. The truth is, however, that Edison did not invent the first Electric Light Bulb. Inventors such as Alessandor Volta has early forms of electric Light dating back to as early as 1800 while Edison as the first Successful test October, 22, 1879. Edison did, however developed the first commercially practical incandescent light.

One example of a modern form of pioneering innovation is the Segway. The Segway is a two wheeled personal transportation device where a person stands upright to ride. It is activate by shifting your weight forward or backward and by using a handlebar to steer. The idea being that segway was to transform the personal transportation industry providing a devise that places riders at an increased elevation in a crowd and provides a stability so that the rider does not needs to dismount when the device comes to a stop. Due to these features, the Segway has become popular for tourism and law enforcement agencies, especially in large crowded events.

The reason I classify the segway as form of pioneering innovation is because this really was the first personal transportation devise of its kind. Previously, bikes, scooters, and motorcycles all had to be moving in order to stay on them. The standing from of the Segway had allowed riders to fully stop without needing to step off a diamond from the device. While if was originally speculated that the Segway would fully transform the industry. It has found a niche market in areas such as law enforcement and tourism. Another product that is a form of pioneering innovation is the GPS. Before th GPS, there really wasn't anything comparable, at least on the consumer market. Most of us remember that first Christmas Season When GPS were the rave. EVERONE was purchasing them, and it was new product anyone who drives car could use. The fascinating thing about the GPS is how quickly it came and how quickly it is going due to technology like our Smartphone. Innovating the

GPS is post for another day, but the GPS truly was as form of pioneering innovation. I have often heard authors or business claim that something essentially falls into the category of pioneering innovation, while the form the innovation was not completely new in one form or another. In our next post, we will explore innovation that come from utilizing industry benchmarks or other industry best practices.

CONTEXT

Innovation is often also viewed as the application of better solutions that meet new requirements, unarticulated needs, or existing market needs. This is accomplished through more-effective products, processes, services, technologies, or business models that are readily available to markets, governments and society. The term 'innovation' can be defined as something original and more effective and, as a consequence, new, that 'breaks into' the market of society. It is related to, but not the same as; invention innovation is often manifested via the engineering process. The opposite of innovation is Enovation.

While a novel device is often described as an innovation, in economics, management science, and other fields of practice and analysis, innovation is generally considered to be the result of a process that brings together various novel ideas in a way that they affect society. In industrial economics innovations readily available to markets, governments and society. The term "innovation" can be defined as something original and more effective and as a consequence, new, that 'breaks into' the market or society. It is related to, but not the same as, invention innovation is often manifested via the engineering process. The opposite of innovation is exnovation.

While a novel device is often described as an innovation, in economics, management science, and other field of practice and analysis innovation is generally considered to be the result of a process that brings together various novel ideas in a way that they effect society in industrial economics, innovations are created and found empirically from serviced to meet the growing consumer demand.

TYPES OF INNOVATIONS

INCREMENTAL INNOVATIONS: Incremental innovation is the most common form of innovation. It utilizes your existing technology and increase the value to customer (features, design changes, etc.) within your existing market. Almost all companies engage in incremental innovation in one form or another. Examples include adding new features to existing products or services or even removing features (value through simplification).

DISRUPTIVE INNOVATION: Disruptive innovations, also known as stealth innovation, involves applying new technology or processes to your company's current market. It is stealthy in nature since newer tech will often be inferior to existing market technology, This newer Technology if often more expensive, as fewer features, in harder to use, and is not as aesthetically pleasing. It is only after a few iterations that the newer tech surpasses the old and disrupts all existing companies. By then it might be too late for the established companies to quickly compete with the newer technology.

ARCHITECTURAL INNOVATION: Architectural innovation is simply talking the lessons, skills and overall technology and applying them within a different market. This innovation is amazing at increasing new customers as long as the new market is receptive. Most of the time, the risk involved in architectural innovation is low due to the reliance and

reintroduction of proven technology. Though most of the time it requires tweaking to match the requirements of the new market.

In 1966, NASA's Ames Research Center attempted to improve the safety of aircraft cushions. They succeeded by creating a new type of foam, which reacts to the pressure applied to it, yet magically form back to its original shape. Originally it was commercial marketed as medical equipment table pads and sports equipment, before having larger success as use in mattresses. This "Slow spring back foam" technology falls under architectural innovation.

REDICAL INNOVATION:-Radical innovation is what we think of mostly when considering innovation. It gives birth to new industries (or swallows existing ones) and involves creating revolutionary technology. The airplane, for example, was not the first mode of transportation, but it is revolutionary as it allowed commercialized air travel to develop and prosper.

The four different types of innovation mentioned here – Incremental, Disruptive, Architectural and Radical – help illustrate the various ways that companies can innovate. There are more ways to innovate than these four. The important thing is to find the type(s) that suit your company and turn those into success.

CONCLUSION

1. Focus on entrepreneurial spirit and value creation processes
 - Co-create the discovery mind-set via open innovation 2.0& societal innovation learning camps.
 - Network with international research and business communities (not only the players from your own region & Member State).
2. Implement RIS3 by involving all key stakeholders (Quadruple Helix)
 - Strengthen your region's RDI capacity building including research and innovation infrastructure, Living Labs etc. to increase the use of EU instruments.
 - Create governance mechanisms to optimize synergies, since substantial parts of the H2020 budget will be delegated to public –public partnerships and public – private – partnerships i.e., EIPs, JTI, ERA – Nets etc.
3. Use RIS3 for the regional economic transformation
 - Focus on building European partnerships through H2020, INTERREG, Macro Regions.
 - Increase synergies between different financial instruments and actors in the RIS3 development and implementation processes.
4. Speed-up the strategic political decisions
 - Focus more on R&D and innovation and co-creating the culture of experimenting, piloting and scaling up to broad use around Europe – and move to action.
 - Create concepts for local collaboration and European partnerships.

REFERENCES

- Allison Graham T. 1972 *Essence of decision* Boston Little Brown.
- Beyuer, Janice M. 1978 'Editorial Policies and practices among leading Journals in four scientific fields *sociological quarterly* 19: 68 - 88
- Braybrooke , D, and C . Lindblom 1963 *a Strategy of decision* New York : free Press
- Burns, Tom, and G.M. Stalker 1961 *The Management of Innovation*. London Tavistock .

- Carter, Eugene 1971 the behavioral theory of the firm and top - level corporate decision. Administrative Science Quarterly 16: 413 – 428
- Dholaka Bakul H. 1978 'Relative Performance of Public and private manufacturing enterprises in India : Total factor productivity approach. Economic and political weekly 13/8 : M4 – M 11.
- Harris Frank Reginald 1959 Jamsetji Nuesserwanji Tata : a Chronicle of his life . 2nd edition Glasgow: Blackie .
- Hoselitic , B.F. 1960 Sociological aspects of Economic growth Glencoe: Free Press

ROLE OF ANGLE INVESTOR IS CURRENT ADVERTISEMENT IN SCENARIO

TARU GUPTA

RESEARCH SCHOLAR

SHRI JAGDISH PRASAD JHABARMAL TIBREWALA, UNIVERSITY
RAJASTHAN

ABSTRACT:-A startup company or Startup is a company in its nascent stage that is just starting to develop. Startups are generally small and originally financed and operated by a small group of founders or just one individual. Startups aim at creating their market by offering products or services that are not currently being offered elsewhere in the market or that it is being offered but of an inferior quality. At the time of induction of a Startup, the expenses tend to exceed revenues as a large chunk of capital is locked down in developing, testing and marketing of the novel idea. At this stage the Startups are in dire need of funding, they try a combination of sources like – business loans from banks or credit unions, or by grants from nonprofit organizations and state governments. The angel investment market has dramatically improved and developed significantly in a number of countries worldwide, particularly over the past 5-10 years. Most innovative tech startups which were born in the past decade have spread their roots and have grown into to large profit making businesses. In countries like India, the government has played an instrumental role in making policies to encourage a greater number of angel investors, in order to encourage their investment. These efforts include supply-side measures such as tax incentives and the creation of co-investment funds.

KEYWORD-MARKETING, BUSINESS, INVESTMENT,

INTRODUCTION:-One common destination of profitable and innovative business ideas are Universities as they hold high potential for start-ups. However, inexperienced students often lack business sense as the innovators focus more on research rather than commercially success and hence more often than not are unable to succeed in securing angel or venture capitals which lead to eventual death of the venture even before it takes off. This is also a glaring example that explains the potential disconnect between innovation policies, which tend to focus on R&D rather than commercialization, and entrepreneurship policies which focus on the translation of innovation into firms.

All Startups go through following stages-

1. Pre-Startup: This phase is characterized by the discovery of a potentially scalable idea, substantial enough target market.
2. Startup: This phase is characterized defining the business model and expanding the customer base in a sustainable model.
3. Growth: This phase is characterized by maximizing benefits and reducing the impediments to the business.

Angel Investor:-As per the standard textbook definition, an angel investor is the first source of external funding when funding from the founder, friends, and families get depleted. An angel can also be defined as “a person who provides capital, in the form of debt or equity, from his personal funds to a private business owned and operated by someone else who is neither a friend nor a family member.” Angel investors can be categorically differentiated from informal lenders like friends and family who have no prior entrepreneurial experience hence differ majorly in their investment approach. Though the profile of angel investors may be diverse, they are generally high net worth individuals who invest in entrepreneurial

ventures as part of an overall portfolio. Angel investors are generally motivated to invest in new ventures, in addition to making money, either to get involved with private companies or to promote a hobby job or to help the community. In recent past Startups have had tough time procuring funding from angel investors because of their strong preference for anonymity, this on many occasions has been the reason for early mortality of large numbers of startups. Angel investing is a relatively new trend in India, where a class of investors who are not part of traditional wealthy families but first generation entrepreneurs are investing their self-acquired wealth in Startups. Following is a list of top ten Angel Investors in India.

Importance of Angel Investors:-Angel investors are also a preferred source of equity over Venture Capital (VC) as they support a wider range of innovations in comparison of VC. Moreover, angel investors do not shy away from investing in a broad range of sectors and do not overlook local startups too. This way angel investors have a broader investment coverage both regarding not only industry but also geography.^[4] Even though angel investing is taken up by experienced business owners and entrepreneurs, it differs greatly from being a financial investor or building a company in a particular sector. It requires a combination of both skill sets as well as specific technical skills regarding conducting due diligence and determining company valuations.^[5]

A congenial entrepreneurial ecosystem is instrumental for successful angel investing to flourish. Startups do not operate in a vacuum. It can only breathe in a healthy entrepreneurial ecosystem in which many stakeholders play a critical role, including entrepreneurs, investors, large companies, universities, governments, services providers, etc. Governments can help by making sure the appropriate legal and financial framework conditions are in place, and policies are encouraging for new businesses to start up and operate profitably.

CURRENT ADVERTISEMENT IN SCENARIO

Rajan Anandan has been an active angel investor in India, Sri Lanka, and the US. He has invested in many Indian start-ups including Capillary, Druva, Webengage, Wiziq, etechies. in, Authorstream, Justeat. Innovize tech, Aurality, Peel works, and Buy the price. By profession, he is the Managing Director of Google India.

Rajan was the Managing Director of Microsoft India, before Google. His leadership and guidance helped Microsoft become the highest performing subsidiary for Microsoft. Prior to working in Microsoft, he was Vice President of Dell Inc.

His passion for technology coupled with his vast experience in spearheading major technology businesses has helped him leverage his expertise to help start-ups build large, exciting businesses. He tends to invest in early stage technology companies and has invested in the internet, mobile and software startups and e-commerce startups in India. Not only this he, is also the Co-founder and Chairman Blue Ocean Ventures, the first Venture Fund and has funded close to 45 start ups. As an investor, he tends to be involved with his portfolio firms and typically helps in making strategic decisions and identifying new business markets. Anandan also opens the doors to potential clients and advisors. Major investments include Phantom Hands, Capillary Technologies, Source easy, 24/7 Techies, TargetingMantra, Instamojo, Culture Alley, Mobile walla, Druva, Sapience, Frrole, My Shaadi. in, Jigsee (acquired by Vuclip), Goonj, TaxSpanner.com, e Techies, exclusively. In (acquired by Myntra), Digilogues, Vide Capital (acquired by Allegro), Hungry Zone (acquired by Just Eat), Peel-Works, Kwench, Athorstream (acquired by WIZIQ), skoolshop.com, WIZIQ.com, author GEN (acquired by Educomp), BuyThePrice (acquired by Tradus).

Anupam Gopal Mittal

Anupam Mittal is popularly known for bringing a revolution in arranged marriage market through his offering shaadi.com.^[8] He has a portfolio of over 50 startups. He is known for backing ideas that have a significant market potential and backs of from those that do not

indicate sustainability and scalability. He also has an inclination in investment for clean technology, consumer internet, and mobile, healthcare. He is a preferred angel investor because he is known for not interfering in the work of founders.

He is also the founder and CEO of People Group, which includes the matchmaking portal Shaadi, property search website Makaan.com and mobile media company Mauj Mobile.^[9] For his work, he was honored by Business Week as one of India's 50 Most Powerful People. He has funded successful startups like Makaan.com, Mauj Mobile, Ola Cabs, Fab Hotels, LetsVenture, Truebil, Ketto and Prop Tiger.

Sanjay Mehta

Sanjay Mehta is a very active angel investor who has been a serial entrepreneur turned angel investor. He is known for his investments in diverse sectors from educations, health, media, online, medical, travel, FnB, retails^[10]. He is from a technology background and hence enjoys working with mobile start-ups, analytics, social & cloud. Having such a diverse background and knowledge has helped him leverage his experience in understanding various nuances of starting and running a startup. He is extremely passionate about encouraging new entrepreneurs and meeting. He has presently invested in 23 companies as an angel investor. He is known for showing interest in early-stage ventures that specializes in big data, marketing automation, productivity enhancement, location services, quick services restaurants and medical devices and has so far refrained from investing in e-commerce platforms. His portfolio has startups like OYO Rooms, Pretty Secrets, Klip.in, Talview, Unbx, Orange Scape, Consure Medical, Fab Alley, Eco Sense Sustainable Solutions, and Poncho. in.

Abhishek Goyal

Co-founder Tracxn, Abhishek Goyal is popularly known as the startup tracker. He has done his B.Tech from Indian Institute of Technology-Kanpur. His multi-faceted talents include him being a man of many parts—techie, entrepreneur, venture capitalist and start-up tracker. He set up Tracxn Technologies Pvt. Ltd with co-founder Neha Singh as a data analytics firm to track start-ups around the world. This start-up data analytics provider has recently launched an Internet platform aimed at helping early investors in mature start-ups sell their shares by connecting them to venture capital (VC) firms and other institutional investors. His startup is presently being used by over 100 venture funds, including Andreessen Horowitz, Google Capital, Sequoia Capital, even some companies such as Drop box.^[11]

Sharad Sharma

After holding prestigious senior management positions with leading technology companies with the most recent one being the CEO of Yahoo! India R&D where he was responsible for product engineering for all emerging markets and for several global products including image search, search monetization, and HotJobs. Sharad Sharma has ventured into the sphere of angel investing after co-founded Teltier, now part of Cisco. He is currently the CEO of Brand Sigma Inc. He has more than 22 years of global experience in the Internet, enterprise software, and infrastructure markets and has a portfolio of startups like [MyPoolin](#), [Wishberry](#), [LetsVenture](#), [Ciafo](#), [Frrole](#), [Apartment Adda](#), [i7 Networks](#) which specialize in these sectors.

He started on this path in 2006, years before such transactions became fashionable. His preferred sectors of investment are— Disruptive tech, cloud, digital, software infrastructure. While investing in startups, he prefers investing in his sectors of preference. He is a hands-off investor and is available for advice, hand-hold and open doors. His major investments till date have been Mobilewalla, HashCube, Druva Software, Kwench, Unbx, Vayavya Labs, Aurus Network, Birds Eye Systems, i7 Networks, Peel-Works, TaxSpanner, Ezetap, Stayzilla, TechFetch.com, Silvan Innovation Labs, iKen Solutions.

Anand Ladsariya

Anand Ladsariya is the CEO and promoter director of Everest Flavours Ltd., a private company which manufactures and exports o Menthol, Peppermint Oil, flavors and fragrances. He Graduated as a topper of his class and also won a gold medal from Bombay University and Post Graduate MBA from IIM, Ahmedabad. He is also involved in various social activities. Previously he was Chairman of CHEMEXCIL, an export promotion organization established by Ministry of Commerce, Govt. of India, for the promotion of exports. [12]

Ladsariya at present has a portfolio of over 35 angel investments, including investment in startups like [Framebench](#), [FindURClass](#), [ConfirmTKT.com](#) and currently actively invests through Indian Angel Network and Mumbai Angels. His investments are generally tech-oriented. Ladsariya's angel investment portfolio also includes businesses in the US, Singapore, and Germany. As an investor, he is accessible to promoters but also non-interfering.

Major investments are Exclusive. In, Aurality, DEXL, Speak well, Frame bench, TONBO, Mobiquest, Algorhythm, Trikal, Svasti Microfinance, Talent Bridge, Green Dust (earlier Reverse Logistics), Orio Hotels, Appsbailey. [13]

Sunil Kalra

Sunil Kalra started investing in 2002. He is an investor known for his adaptability to venture into new sectors with no or little prior experience. His initial investment w in the real estate sector, and currently, his portfolio has expanded into startups varying from education, healthcare, and e-commerce. His approach is agnostic and Airwoot, Orange Scape, Crayon, Culture Alley, Wooplr, and My Shaadi.in have all been funded by him.

He is known for his is choosy investment choices. Though he has fairly less background in tech startups, he is interested in venturing into them due to their sustainable growth model. Additionally, he is also a member of the Indian Angel Network, and a founding member of the University of Petroleum and Energy Studies in Dehradun, Uttarakhand.

Rajesh Sawhney

Rajesh is the Founder of Super Angels of India. He has a vast experience in entertainment, media, and communication sector which also includes his last association with Reliance Entertainment Private Limited as president for seven years.

He has also built Indiatimes.com from a start-up venture. During his 14 years stint with BCCL, he created successful businesses across several new areas, including publishing, Radio, TV, retailing, internet, e-commerce, travel and mobile VAS. He is based in Mumbai.

TV Mohandas Pai

Mr.T.V. Mohandas Pai has brought his decades of operational and leadership experience in his startup investing ventures. Mr. Mohandas is the Chairman of Manipal Global Education, he is also an ardent supporter of the Akshaya Patra Foundation and is one of the members of the board of trustees of Akshaya Patra. [14] In the past, he has served as a Member of the Board of Infosys from May 2000– July 2011. He has won several accolades in the form of 'CFO of the Year' in 2001 by IMA India, the 'Best CFO in India' award from Finance Asia in 2002, and 'Best chief financial officer in India' in the Best Managed Companies poll conducted by AsiaMoney in 2004. From 2012 when he started investing, he has funded startups like SAHA fund, Zoomcar, Zimber, Uniken, YourStory, Kaaryah and FairCent. Currently, Mr.Pai is focusing on developing a funding ecosystem, which consists of more than ten funds to fulfil capital requirements for an entrepreneur. [15]

RehanYar Khan

RehanYar Khan is an Indian venture capitalist and founder and operator of Orios Venture Partners., a Mumbai-based venture fund for technology startups. Orios is the largest domestically raised venture capital fund in India. Khan has been recognized as one of India's leading early-stage technology investors.

Before moving into venture capital investing, Khan was an active entrepreneur, heading the development of three companies: Fresh Floritech, VSG Services, and Flora2000. He has been the angel investor for Druvawhich provides data protection for computer networks. Since then hKhan has led 19 startup investments including leading investments in OlaCabsJigsee (acquired by VuClip), Sapience, Ziffi, PrettySecrets, Zapstitch and other companies. Not only this, in order to encourage angel investing he became part of Indian Angel Network's Mumbai Chapter.

What Angel Investors Seek while Investing

When an angel investor especially one with a profile like the angel investors mentioned in the above list look for new ventures to invest his funds his chief concern is – Can he afford to lose the money if the startup sinks? This is the first thing that a Startup seeking funds needs to affirm the investor that their reputation won't be in jeopardy if the startup fails to work. In return, the startups have to be mindful of the time the investor can devote to offer advice, and how much time he/she can fruitfully commit. In addition to this, the question also arises about the quantum of capital the investor is willing to invest and in return of what consideration. For startups, it is necessary that the investor that the investor is supportive of their venture and is willing to offer time and advice. Getting funding from angel investors isn't easy, but it can be done if the startups take the right approach and are a good match with their interests. And the benefits can go beyond the money for your business, but their expertise in both in business operations and your industry niche.

Conclusion

Angel investors collectively invest millions of rupees in startup and entrepreneurial ventures yearly, they are usually the first outsiders to supply startups the much-needed equity to kick start the startup business. Angel investing goes beyond the desire to make money for investors, it has more to do with the passion to uplift budding entrepreneurs and pursuing one's own passion by being an angel to the venture one wants to help succeed. Angel investing has a lot to do with the grit and the knack for taking a risk and less about being a mere money lender to business. Angel investors have been sparse in number and hard to find as they prefer to keep themselves discrete. Financial institutions have always been hesitant about lending startups, small, young firms due to the perceived riskiness of future prospects and lack of guarantee in the form of collateral. This scenario has considerably altered due to a surge in angel investing by young entrepreneurs who have acquired considerable equity and now want to venture in new, contemporary ideas.

The lack of an entrepreneurial culture in many economies has been witnessed as a critical barrier to entrepreneurship. Without entrepreneurs, there will not be any start-ups. Changing culture is difficult and requires a long-term effort, but the scenario is slowly changing for the benefit of startups as more risk-bearing angel investors are showing an inclination towards contemporary business ideas which do bear a high risk of failure with them. Passion has always been the mean driving force for angel investors over time. Emerging and growing economy like that in India is an ideal environment for startups and angel investors to flourish due to the huge consumer base. Startups play an important role in promoting local business and talent; it has recently become an importance and in-severable limb of the entrepreneurial ecosystem.